

PAPER • OPEN ACCESS

A Mission Exchange Model (MEZ) for Autonomous Inland Waterway Navigation

To cite this article: Marianne Hagaseth *et al* 2025 *J. Phys.: Conf. Ser.* **3123** 012012

View the [article online](#) for updates and enhancements.

You may also like

- [Continuously variable spreading exponents in the absorbing Nagel–Schreckenberg model](#)
Ronald Dickman
- [Optimizing the design of bipolar nerve cuff electrodes for improved recording of peripheral nerve activity](#)
Parisa Sabetian, Milos R Popovic and Paul B Yoo
- [ENERGY CONSERVATION AND GRAVITY WAVES IN SOUND-PROOF TREATMENTS OF STELLAR INTERIORS. PART I. ANELASTIC APPROXIMATIONS](#)
Benjamin P. Brown, Geoffrey M. Vasil and Ellen G. Zweibel



ECS The Electrochemical Society
Advancing solid state & electrochemical science & technology

250
ECS MEETING CELEBRATION

*Step into the
Spotlight*

**SUBMIT YOUR
ABSTRACT**

250th ECS Meeting
October 25–29, 2026
Calgary, Canada
BMO Center

Submission deadline:
March 27, 2026

A Mission Exchange Model (MEZ) for Autonomous Inland Waterway Navigation

Marianne Hagaseth^{1*}, Håvard Nordahl¹, Lars Andreas Lien Wengersberg¹, Hans-Christoph Burmeister², and Øyvind Pedersen³

¹ Maritime ICT and Cybernetics Group, Energy and Transport Department, SINTEF Ocean, Trondheim, Norway

² Fraunhofer CML, Hamburg, Germany

³ Maritime Robotics, Trondheim, Norway

*E-mail: Marianne.Hagaseth@sintef.no

Abstract. Even if autonomous vessels can operate independently of a person monitoring or controlling it on some parts of the voyage, a Remote Operation Centre (ROC) is still needed. The ROC operator will be responsible for planning the voyage and to follow up on its operation. Also, the ROC operator will be responsible for handling those situations where human interventions are needed, either unforeseen situations, interactions with crewed vessels, or planned interaction with other operation centres, e.g., for bridges and locks. For an autonomous vessel to navigate on inland waterways (IWW), a clear description of the operations must be provided to the onboard Autonomous Navigation System (ANS) by the ROC operator. Further, the description of the mission must be sent from the ROC to the vessel and be handled by the ANS onboard to conduct the sailing from the departure to the arrival berth, including lock- and bridge passing. In this paper, we describe the requirements to a Mission Exchange Model (MEZ), investigate existing and relevant standards that cover mission data, and propose a format for such missions to be sent from the ROC to the ANS. We will also describe how the planning of the mission can be performed in the ROC, and we will present a test run with an autonomous sea drone that was performed in Trondheim, Norway, in 2025, to show case the usage of some parts of this MEZ.

1. Introduction

Humans will be involved in the operation of autonomous vessels for the foreseeable future, irrespective of whether the autonomous vessel is capable of navigating inland waterways (IWW) without continuous human supervision for certain parts of the voyage. The established principle of autonomous navigation, somewhat simplified, is that a) the Situation Awareness System (SAS) provides the Autonomous Navigation System (ANS) with the required information to perform navigation, such as positioning, traffic and other objects, b) to navigate autonomously, the ANS must determine if the actions it currently executes, such as docking or transit, can commence as planned, or if corrective actions such as speed and course changes are required, and c) that the operator intervenes if deemed necessary or requested by the ANS, or otherwise monitor the operation, Figure 1. This principle emerged very early in autonomous vessel development [1], and is reflected in the ongoing IMO MASS Code development and international standardization [2], as well as within the first commercial IWW applications.



Content from this work may be used under the terms of the [Creative Commons Attribution 4.0 licence](https://creativecommons.org/licenses/by/4.0/). Any further distribution of this work must maintain attribution to the author(s) and the title of the work, journal citation and DOI.

Although the autonomous navigation system should be capable of making decision on its own, it cannot determine its own purpose, that is, what it is supposed to do. Thus, it falls upon humans to tell the autonomous vessel what it is supposed to do, when it is supposed to do it, where it is supposed to be at given times, and what navigational constraints it must consider. This is the mission, and that is assigned to the autonomous vessel by a remote operator that resides in ROC, before leaving the departure port.

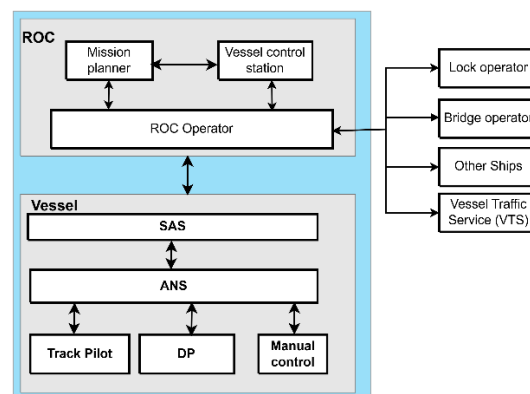

Figure 1. Environment for IWW Mission Planning and Execution

The remainder of the paper is structured as follows. Section 2 will give background and context for the work, and an overview of the IWW vessel operation. Section 3 describes the methodology we applied to create the mission exchange model. Section 4 presents the MEZ whilst results from a scaled-demo of parts of the MEZ is presented in Section 5. We draw conclusions in Section 6 and explain what further work are relevant.

2. Background and Context

2.1. Related Work on Route Planning and Autonomous Navigation

In manned maritime transport, one core task of navigation is voyage planning, which serves as the backbone of safe navigation. Voyage planning is linked to SOLAS Regulation 34 [3], with IMO Resolution A.893(21) giving guidelines on how to execute this task [4]. The plan itself typically consists of amongst others: Plotting of the intended route, safe speed, necessary speed alterations, minimum clearances, and course alteration points. Since 2015, this is electronically supported by a route plan exchange format, which is called RTZ, and standardized by CIRM [5], and also standardized in IEC 61174:2015, Edition 4 [6]. This was tested for vessel-shore interaction capabilities by the STM project [7]. An extended version of RTZ, named S-421 and developed by IEC as IEC63173-1:2021 [8] is added to the IHO S-100 framework of standards. Also, during the ISTS-project, a converter from the RTZ-format to the S-421 format was implemented [9]. Routes in RTZ and S-421-formats are described by geographical waypoints, allowed cross track errors, schedules, and optionally by a simple turning radius between legs. On open sea, such voyage plans can be executed from a track pilot supervised by an officer of the watch. In inland navigation, similar processes apply, yet less formalized.

For Autonomous and Inland Navigation, additional specific data elements need to be covered, which are not yet included in the given voyage planning data format, including 1) Specific geometries: The meandering nature of (natural) IWW requires more complex route planning than static turning radius. State-of-the-art track control systems for IWW do typically work with rotation speed regulation instead. 2) Infrastructure interactions: Pausing and waiting during a

voyage at IWW infrastructure such as bridges and locks, are more common on the voyage than in maritime. Those do typically affect the schedule, which cannot be totally preplanned. 3) Changing autonomous operations: In contrast to manned shipping, different modes of operations (autonomous and remote) as well as different degrees of autonomy (CCNR 0-5) are possible during different parts of the voyage and need to be planned.

Significant efforts have been put into studying autonomous navigation systems where the focus has been on the ROC [10], [11], [12], [13], the Guidance, Navigation and Control (GNC) methods of the ANS [14], [15], [16], [17], support functions of ROC and other shore-based personnel for anomaly detection [18], [19], and also on communication issues [20], [21]. However, less attention has been given to how the ROC should communicate plans, and changes to plans, to the ANS. This includes the definition of the mission that the ANS shall execute, and how it should be exchanged between the ROC and the ANS.

The review in [22] investigates the current advancements on autonomous mission planning and management for autonomous underwater vehicles and aerial vehicles. While a high-level architecture for a typical mission planning and management system is presented, the mission exchange model is not discussed. The review of mission planning in [23] discusses the decomposition hierarchy of the USV (Unmanned Surface Vehicle) mission into specific goals, tasks, and behaviour, however, neither the mission creation nor a data model for transferring a mission from a control centre to the USV is discussed. Robust mission planning for Autonomous Marine Vehicle fleets is proposed in [24], where the planner translates mission goals to tasks that are distributed over the fleet of autonomous drones. However, a mission exchange model is not discussed. An AI planning module for executing the autonomous vessel mission, intended as a translator between the mission and the path and motion planning unit, is proposed in [25]. However, neither the mission creation nor the mission exchange model is discussed. Temporal mission planning for Maritime Autonomous Surface Ships (MASS) is proposed in [26], where an temporal AI planning is used to create the control tasks for the GNC. It takes goals and actions as inputs, but the mission exchange model, that would contain these goals and actions to be communicated between the ROC and the vessel, is not discussed. While the literature seems to focus on the planning problem from the perspective of translating mission goals into tasks, to the best of the authors knowledge, no studies address the data model for transferring the mission to the ANS.

In this paper, we propose a *Mission Exchange Model*, which is the data model for the mission to be sent from the ROC to the IWW vessel. This data model will be based on existing standards for route plan exchange (RTZ for current usage[5] and S-421 for further usage[8]) and standards for IWW navigation (currently IENC 2.4 [27], and future S-401[28]), as well as class terminology for autonomous operations (as e.g. DNV Autoremote [29] or CCNR[30]), to be easily adapted by existing technologies. The mission exchange model will contain all the information that the autonomous vessel will need to execute a mission, including relevant information about the cargo, departure and arrival berths, the route to navigate (with any restrictions such as shallow draft), with the related schedule, bridges and locks to pass, and the allocated positions in the lock chambers and at the berth derived from the Inland ENCs.

2.2. Overview of IWW Vessel Operation

Figure 2 describes the message exchanges related to the planning, execution and updates of a mission, related to the environment shown in Figure 1. The process starts with the ROC operator describing the mission, including the route and waypoints, planned speed over ground, time schedule, cross track distance for each leg, if the ANS or the ROC operator is in control for each

leg, information about the lock passing and bridge passing, and information about when the ANS should notify the ROC operator and what situation to report on. The Mission planner in the ROC will create the Mission Exchange Message according to the Mission Exchange Model, and this will be sent by the ROC communication interface using the ANS-ROC communication carrier.

The ANS will need to validate the mission, and it will then send the approval back to the ROC operator. Then, the mission is ready for execution by the vessel. The ANS can either execute the mission by sending the set points to the Track pilot or DP system, or it can instead hand over the control to the ROC operator, dependent on the instructions in the mission. During the execution of the mission, the ANS will continuously send statuses and feedback to the ROC operator, according to the mission, and to what is already defined by the ANS. For each request, the ROC operator must evaluate the request and act as needed. This may be to take over the control of the vessel from the ANS, to contact lock or bridge operators, or to handle some requests that requires updates of the mission plan. During the execution of the mission, external actors as lock or bridge operators may also give warnings or information to the ROC operator that may lead to updates of the mission plan.

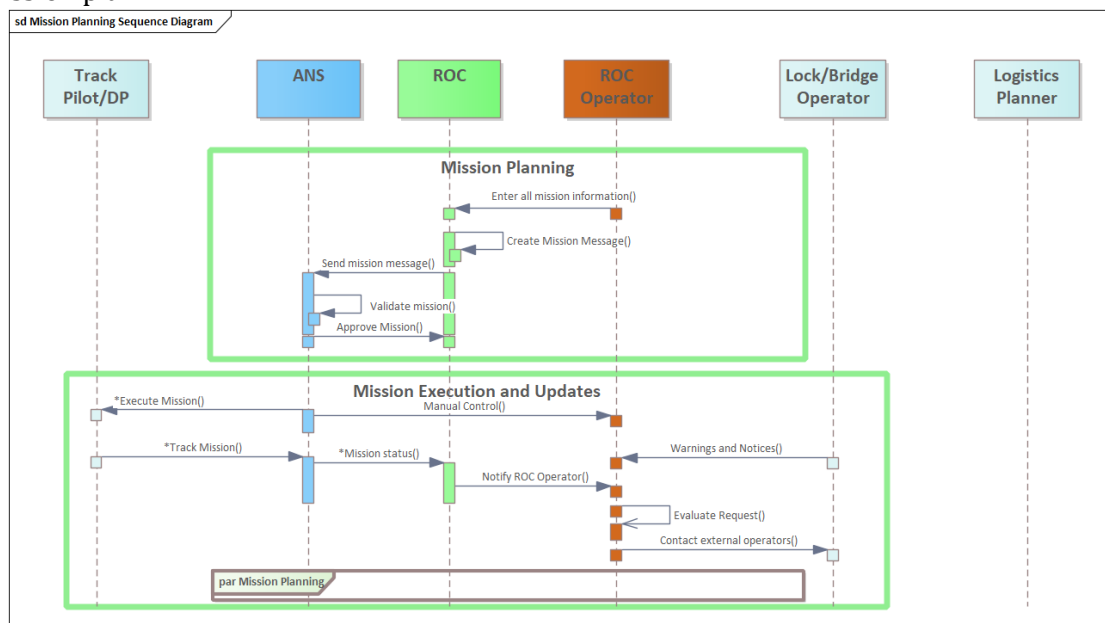

Figure 2. Mission Exchange Message sequence diagram

3. Methodology

3.1. Overview

To develop the mission exchange model, we applied a case study method. The case study was designed to be carried out over four phases, with each phase having a specific purpose:

- *Requirements:* In the first phase, we elicited requirements to the mission exchange model in a series of online workshops with joint industry and research organisations represented by the authors of this paper, see Section 3.2.
- *Gap Analysis:* Secondly, based on the identified requirements, we did a review of existing data models and standards applicable to inland waterways, but also standards for sea-going vessels. We investigated which parts of these existing standards could cover which of the requirements to the Mission Exchange Model, and which gaps that still existed, see Section 3.3.

- *Extended Data Models:* Thirdly, we proposed new data elements that are extensions to the existing models and standards to cover the mission exchange data between the ROC and the autonomous vessel that are not already covered. These extensions are proposed as UML classes that can be further implemented as messages on XSD-format or other formats, see Section 4.
- *Demonstration:* Fourth, and finally, a part of the mission exchange model was implemented and demonstrated on a scaled demonstration vessel (OtterX) as proof-of-concept, see Section 5.

3.2. Requirements to Mission Exchange Model

The requirements to the Mission Exchange Model were collected during online workshops with AutoFlex [31] project partners, and this can be summarized as follows:

- The mission exchange model covers data needed to be sent from the ROC to the ANS to define the navigation from a departure berth in a terminal to the arrival berth in the arrival terminal.
- The mission exchange model covers data needed to be sent from the vessel to the ROC regarding situations detected by the vessel that needs attention by the ROC operator.
- The mission data model does not cover data sent between the ROC and the lock/bridge or other shore-based infrastructure.
- The vessel travels a fixed route, from a departure port to an arrival port. The vessel will need information about the mission before it leaves the departure port.
- Details on the communication protocol between the ROC and ANS is not part of the mission exchange model.
- The vessel does not have interface to the RIS (river Information System), as this is only handled by the ROC.
- The vessel is assumed to be on at least level 4 of automation (high automation) according to the CCNR definition of levels of automation in inland navigation [32], where the vessel is capable of operating between two successive locks.
- The ANS sends status information continuously to the ROC for the ROC operator to monitor the sailing and also to get sufficient situational awareness in those cases where the ROC operator needs to take over control or to update the mission.
- The vessel is able to handle situations in its vicinity through its autonomous navigation system and situational awareness functionalities.
- A mission update is sent from the ROC to the ANS when changes to the mission is needed. This avoids problems with latency of communication.
- The vessel notifies the ROC when it enters a fallback state, which needs to be handled by the ROC.

Another important part of the mission is to ensure that the handover between the ANS and the ROC operator is correctly handled, i.e., to ensure that sufficient information is available among the mission data to send notifications between the vessel and the ROC operator. This includes pre-planned actions defined by the ROC operator that must be performed by the vessel, for instance the mission may contain certain waypoints where the vessel shall stop, notify the ROC, and await acknowledgement or further instructions before proceeding, such as bridges that needs to be opened before passing. This can also be a point where the vessel shall do a transition between two voyage phases that requires the ROC operator to either do an action or to verify information before the vessel can proceed. One example is that the remote operator must communicate with a lock operator via VHF before entering the first lock chamber. Another example is to visually

verify that the berth is clear before initiating automatic mooring. A third example of an action point is a point where a pre-planned transition from one operational mode to another is performed, e.g., from automatic navigation to ROC operator-controlled navigation. This transition of operational mode may for instance be needed when the vessel is about to enter a lock.

3.3. Gap Analysis of Existing Standards

IWW traffic is not regulated through IMO by COLREG or SOLAS, but by regional and national regulations. For Europe, CEVNI (European Code for Navigation on Inland Waterways) regulates the navigation of most of Europe's rivers, canals, and lakes [33]. During this work, we have therefore looked at the regulations of inland ENC. However, we have also investigated definitions from IMO, to reuse as much of existing definitions as possible.

For information that is specific for inland waterways, e.g., for locks, bridges, and the signalling requirements when sailing on the rivers and canals, we have used information from the iENC regulations.

The Mission Exchange Model was described as data types and data elements in a UML model based on the IWW use case (first step), a walk-through of the following standards (step 2), and a gap analysis of these:

- The S-421 standard (IEC 63173-1:2021) on route exchange [34] is reused when it comes to the definitions of routes, legs, waypoints, action points, and the schedule.
- The current Inland ECDIS Standard Edition 2.4 [35] and the IENC Feature catalogue [27] were used to find specifics related to the IWW sailing, lock passing and bridge passing, that is not covered by S-421.
- The upcoming S-401-standard for Inland Electronic Navigational Charts [36],[28] when it comes to information about port features.
- The EDIFACT message BAPLIE regarding the bayplan/stowage plan describing container related data on weights and dangerous goods [37] when it comes to cargo information needed by the IWW vessel.
- The reference model and list of data elements as described in the IMO compendium [38] when it comes to static information about the vessel.

4. Description of Message Exchange Model (MEZ)

4.1. Overview

Figure 3 gives a simplified overview of the interaction between the ANS onboard the vessel that is used during the mission execution and the person in the ROC that follows up on the vessel. The rounded boxes show different activities handled by the ROC operator and the vessel. The arrows show transitions between these activities.

1. Green boxes: Initially, the ROC operator plans the mission for a vessel. The operator uses the mission planning tool to set up the route, timetable, and action points. The mission message is generated and sent to the vessel for approval and execution. During the voyage, the ROC operator can also update the mission based on input received during the monitoring or the controlling of the vessel.
2. Blue boxes:
 - a. After the initial planning of the mission has been done, the ROC operator works in one of two modes: Remote control of the vessel or monitoring the vessel.
 - b. The vessel either controls the sailing by executing the mission or it is passive while being remotely operated by the ROC operator.

When it comes to controlling the vessel, either the automation onboard or the ROC operator must be accountable for the operation of the vessel, not both at the same time. This means that when the vessel is executing the mission, the ROC operator will monitor the vessel. When the ROC operator is remotely controlling the vessel, the vessel is manually controlled and the ANS is not used.

3. Light yellow boxes:

- a. The vessel must continuously send its statuses and requests to the ROC for further processing by the ROC systems and the ROC operator.
- b. The ROC operator must interact with external persons and system, both during monitoring and during remote control operation.

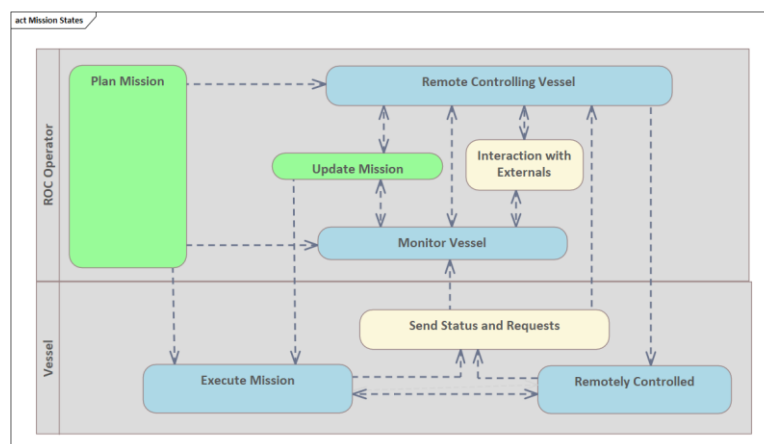

Figure 3. Phases and Interactions between Autonomous IWW Vessel and the ROC Operator

The Mission Exchange Model contains of two parts: A) *Mission planning data*, that is needed for the planning of the mission, and is sent from the ROC to the ANS, and B) the Mission execution data that is sent from the vessel (ANS) to the ROC during vessel operation.

A) *Mission planning data* that are sent from the ROC to the ANS to inform the ANS about the details of the passage from the berth in the departure port to the berth in the arrival port. This describes the planned mission to be approved and executed by the ANS:

- *Planned route and planned actions, Section 4.2.*
- *Planned schedule with planned actions, Section 4.3.*
- *Mooring, Section 4.4.*
- *Planned autonomy level, Section 4.5.*
- *Cargo, Section 4.6.*

B) *Mission execution data* that are sent from the ANS to the ROC during execution of the mission. This information comes in addition to the sensor data sent from the vessel to the ROC, see *Section 4.7.*

4.2. Planned route and planned actions

Figure 4 shows the UML classes representing the data for planning the route legs and for specifying action points. The light brown boxes are a simplified view of the classes from S-421 Route Exchange, while the green boxes represent additional classes defined to cover the IWW mission planning.

- Information about Action Points: The current version (June 2025) of S-421 defines the action point either as a point, as a circle with a position and a diameter, or as a user defined space

geometry. This mission exchange model will allow action points of all these types. Several action points can be defined for each route. They are linked directly to the route, and not necessarily to a waypoint. The following extra data is needed for the mission exchange model compared to S-421:

- *Extra data related to Action Point:*
 - A route action point type (*RouteActionPointType*) is needed to explain the type of action related to a specific route action point. This can be for instance a radio calling-in point, an area indicating a traffic signal station for a bridge or lock passing or port entry and departure, an area indicating that communication with VTS, locks, bridge etc. can be done. These values are derived based on the Encoding Guide for Inland ENCs [35]. In addition to this comes action point types to indicate that the lock passing and bridge passing need to be done remotely controlled by the ROC operator.
 - The enumeration *RouteActionPointRequiredAction* is extended with a value for *MissionAction* to indicate that the action point is used in relation to a mission plan.
 - *ShipPlannedActionPointRequest*: This is a list of different notifications that the ROC operator expects the ANS to do related to an action point, or at some other point in time. Examples are to notify the ROC operator when entering (ATA) or leaving (ATD) the action point area, notify about the expected arrival time (ETA) or expected departure time (ETD), or instruct the ANS to notify the ROC operator when a green light or unknown object is detected. The value of attribute *routeActionPointTimeToAct* in *RouteActionPoint* is used to describe the point in time when the notification should happen, for instance how long time before the ETA or ETD should be given.
- *Extra data related to Legs between two Waypoints:*
 - A route is defined by a list of route waypoints. The legs of the route are defined between two route waypoints with information related to this leg describing the centerline of the leg, the crosstrack distance to port and starboard (*routeWaypointLegPortXTDL*, *routeWaypointLegStarboardXTDL*), and the broader clearance to port and starboard defined by *routeWaypointLegPortCL* and *routeWaypointLegStarboardCL*.
 - The following extra information is needed for the legs in the mission:
 - For each leg, the ROC operator plans a list of requests that the vessel must perform for this leg. This is defined in *ShipPlannedWaypointLegRequest* and includes notifications saying that the vessel has moved outside the PortXTDL line or StarboardXTDL line. It also includes notifications that the vessel has entered a fallback state because the vessel has moved outside the PortCL line or StarboardCL line.
 - In addition to this, a level of autonomy and notification deadline is defined for each leg.
 - Note that the planned SOG for the leg is defined in the *RouteScheduleElement* (a data element in S-421) as *RouteScheduleElementPlanSOG* related to the end waypoint of the leg.

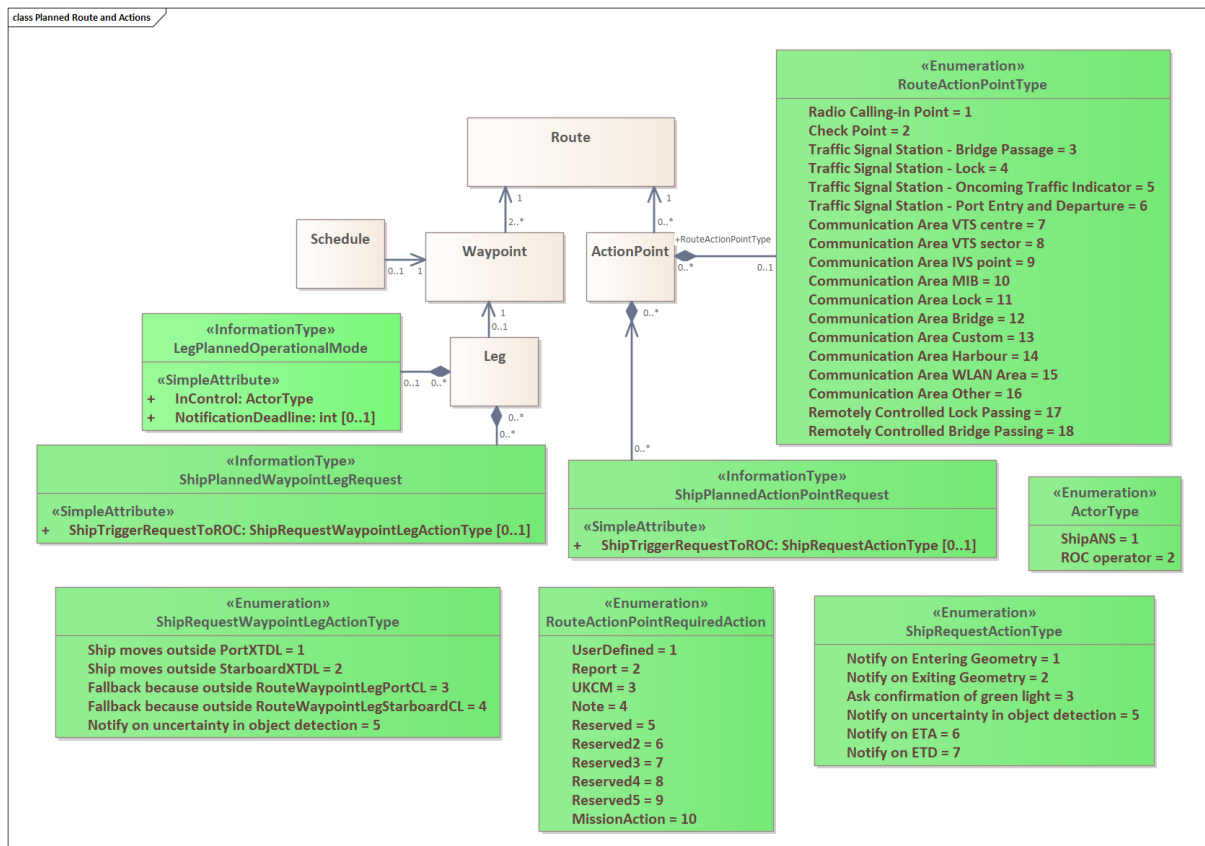

Figure 4. Planned Routes with Planned Actions and Waypoints

4.3. Planned schedule with planned actions

Figure 5 shows in green boxes the extra data types that are needed to describe the time schedule for the waypoints in the route that are part of the mission. The light brown boxes show data types from the S-421 route exchange standard (simplified). For our usage, the *RouteScheduleElement* only needs to be related to the Waypoint class, and not directly to the route class. Also note that action points do not have schedules attached to them.

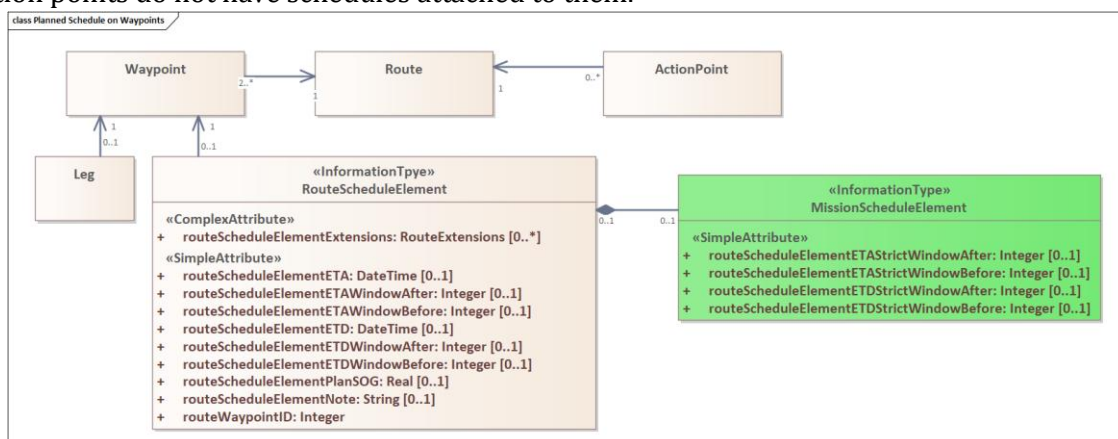

Figure 5. Planned schedules on waypoints

The *RouteScheduleElement* describes the ETA to the waypoint, the ETD from the waypoint, and a time interval in number of minutes before and after the ETA and ETD. It also includes the planned speed over ground to be used when approaching the waypoint. The time intervals for

entering and leaving a waypoint are the planned time intervals that the ANS onboard need to adhere to. However, it will also be useful for the ANS to know the strict limits of the time intervals for each waypoint when executing the planned route. These restrictions may for instance happen due to closing hours of the locks and bridges, or because of the tide that makes it necessary to reach a waypoint or leave a waypoint no later than at a specific point in time. These restrictions are described in the data type *MissionScheduleElement*.

4.4. Mooring

For a mission to be completed, the ANS needs information about the mooring position and how to moor and unmoor the vessel. For this information, we use the descriptions in the standard S-131 on Marine Harbour Infrastructure. These data types are further described in [39]. Only some of the data elements in this standard are needed to describe the mooring.

4.5. Planned autonomy level

According to the Central Commission for the Navigation of the Rhine [32], the level of autonomy for IWW is one of the following modes of operation: No automation, steering assistance, partial automation, conditional automation, high automation, or full automation. However, the mission plan will need a simpler definition of the autonomy. Therefore, the planned level of autonomy is described by the information shown in Figure 6. This gives an overview of the data types needed to describe the planned level of autonomy for a whole route (*DefaultOperationalMode*), for a leg (*LegPlannedOperationalMode*), or for an action point (*ActionPointPlannedOperationalMode*). The operational mode is described by who is in control and a notification deadline. The notification deadline is the maximum time (in minutes) that the vessel will wait for a response from the ROC operator, before the vessel goes to a fallback state. The autonomy level is described by who is in control of the vessel: This can be either the *ROC operator* or the *ANS onboard* the vessel. This party is both controlling the vessel and is also accountable, which means that this party is capable of getting sufficient situational awareness in time to operate safe. At each point in time, only one party can be in control.

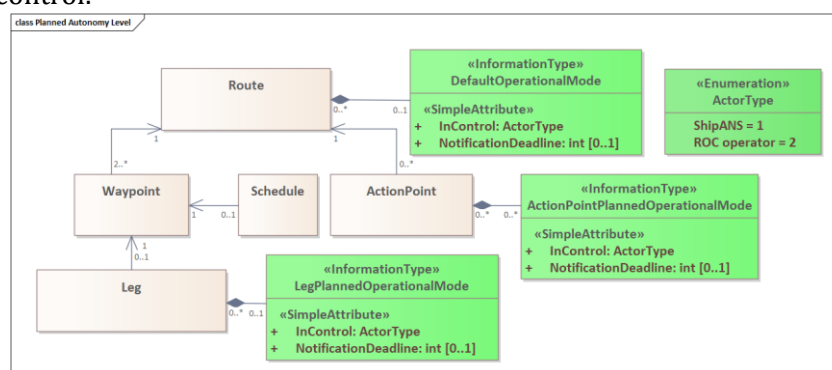

Figure 6. Data types for planned autonomy levels

4.6. Cargo

Cargo data may be needed as a part of the Mission Exchange Message in some cases. If present, the Cargo data is related to the whole route, and may contain the following information:

- The stowage location onboard the vessel
- The ID of the container
- The UNDG number and hazard class in case of dangerous goods
- The weight of the container

Also related to the container data, is the height of the vessel if stacked one, two or three on top of each other. This data is given as part of the vessel static data at the Route level.

4.7. Mission Execution Data

This section describes the data that is needed for the ANS to send to the ROC to notify about the execution of the mission. This execution data comes in addition to the other ANS status data that is sent to the ROC. Figure 7 shows the data model for the data that is needed to be sent from the ANS to the ROC. The following data types are needed:

ShipDynamicData: This is the vessel movement data at the time of reporting from the ANS to the ROC. This is defined as described in the IMO Compendium [38].

ShipActualMissionData: This data type is used to send actual information from the ANS to the ROC to indicate whether the ANS has approved the mission, started the mission, or requested an update of the mission.

ShipActualRequest: This data type is used to send actual information from the ANS to the ROC related to a specific action point. This can be a notification that the vessel will enter or leave the area related to the action point. The type of this area is one that is listed in the enumeration *RouteActionPointType*. The notification can be sent when actually entering or leaving the area, or it can be sent in advance. Then, the actual time for entering or leaving the area, is indicated by ETA and ETD, respectively. An example is that the ANS can send a notification to the ROC, saying that the vessel will arrive at a Communication Area Lock (see *RouteActionPointType*) at the time ETA. The ANS can also request the ROC to confirm a green light (see *ShipRequestActionType*), to check an object that the SAS is not able to identify, or it can be to notify about an ETA or ETD to an action point.

The ANS can also give statuses on the schedule to the ROC. This is done by the data type *ShipActualScheduleRequest*, where the new ETA and ETD to the waypoint can be given. Alternatively, information about how the time window will be violated, can be given as indicated in the enumeration *ShipRequestScheduleType*.

Also, the ANS needs to give information about the current position to the ROC operator, to allow the ROC operator to assess the situation and to take action, for instance to take over control of the vessel. This information is related to a certain leg, as described in *ShipActualWaypointLegRequest*. The actual position can be given by latitude and longitude. Alternatively, the position can be an indication of whether the vessel is outside the crosstrack distance (outside *PortXTDL* or *StarboardXTDL*), meaning that the ROC operator may not need to take over immediately, but instead have time to handle the situation in some other way. If the vessel reports to be outside the fallback corridor (*PortCL* or *StarboardCL*), the ROC operator needs to take immediate action, since the vessel has moved into a critical area compared to what has been planned for this leg.

5. Demonstration of the MEZ on an USV in the Trondheimsfjord

5.1. Demonstration Setup

The MEZ will be implemented by Maritime Robotics and tested during the demonstration event of the AUTOFLEX project. As part of the preparations for this demonstration, a subset of the MEZ was tested during a scaled demonstrator with the ROC and USV OtterX from Maritime Robotics [40], in a small canal in the Trondheim city centre in Norway. The scaled demonstration aimed at validating navigation according to a mission as follows, Figure 8: Navigate from a starting point along a predefined track. At action point 1, notify the ROC that the bridge operator must be

contacted for opening the bridge. Continue navigation to action point 2, stop and hold position until confirmation is received from the ROC that navigation can commence. Continue navigation to action point 3, stop and hold position for further instructions.

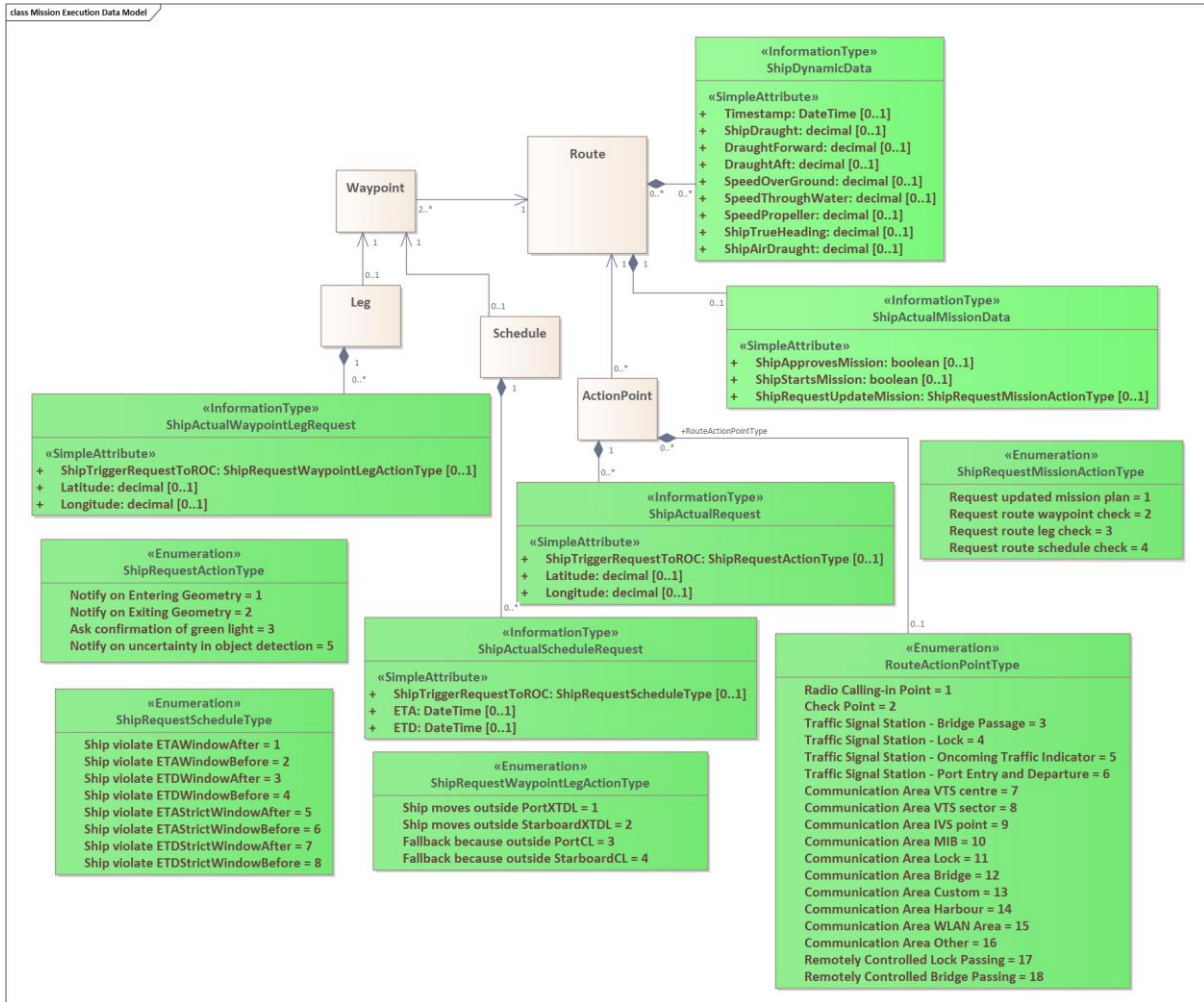

Figure 7. Mission execution data



Figure 8. Mission for the demonstration

5.2. Report from demonstration with OtterX

The demonstration was conducted on June 13th 2025. All planned features and objectives were successfully demonstrated. The initial conditions of the demonstration were that the OtterX was positioned at the planned starting point and confirmed to be in correct operational state, Figure 9.



Figure 9. OtterX and ROC ready for demonstration

The demonstration was started by the ROC uploading the Mission Exchange Message to the OtterX, Figure 10. Then, the ROC initiated the mission by giving a command to the OtterX. The OtterX started tracking the route autonomously, at the pre-defined speed, while the ROC operator continuously monitored the execution of the mission. Upon reaching action point A1, the OtterX notified the ROC that it needed to contact the bridge operator for negotiating bridge opening, triggering a prompt to the operator, see Figure 11. The ROC contacted the bridge operator via phone and coordinated the bridge opening. Meanwhile, the OtterX proceeded to action point A2 where it stopped and held position, awaiting confirmation from the ROC that it could continue tracking the route, see Figure 12. The ROC operator visually confirmed that the bridge was open and light signal indicated clearance, before sending a continue mission command to the OtterX, Figure 13. The OtterX resumed autonomous navigation along the preplanned route. Upon reaching action point A3, after clearing the bridge, the OtterX stopped and held position, awaiting further instructions from the ROC, Figure 14.

A demonstration with a complete Mission Exchange message implementation is needed, and this is planned later in the AutoFlex project where a full scale demonstration in inland waterways is planned. This demonstration will be based on a ship instead of the OtterX USV and will take place in a canal.

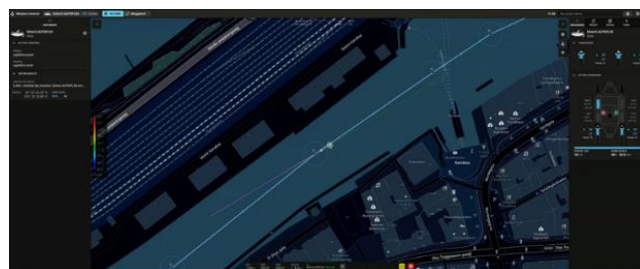

Figure 10. Mission plan loaded and ready

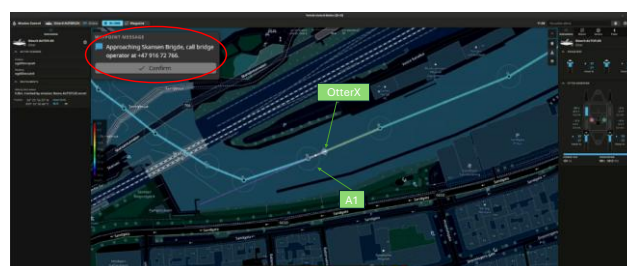

Figure 11. Prompt notification to ROC operator; OtterX position and action point A1

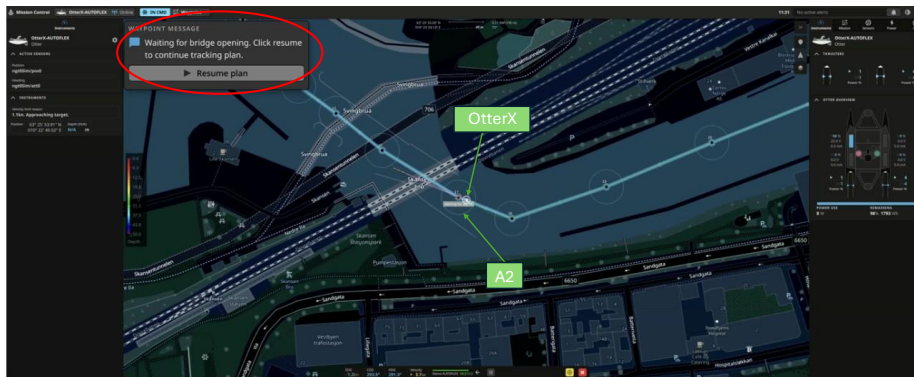

Figure 12. Prompt displaying that OtterX is awaiting confirmation to proceed. OtterX at A2 position

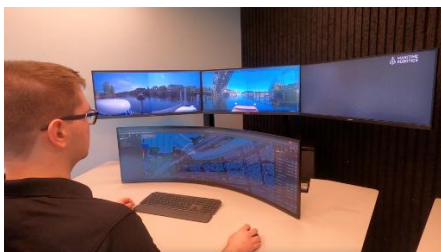

Figure 13. Operator using onboard SeaSeight camera to confirm bridge opening and clear for passage.



Figure 14. OtterX autonomously navigating to final action point A

6. Conclusion and Further Work

This paper has presented a Mission Exchange Model to be used by the ROC when sending the description of the route, schedule, and lock and bridge passings to an IWW vessel. The work shows that existing standards for route exchange currently used by sea-going vessels are a good starting point when defining the data needed for autonomous IWW vessels. It also shows that extensions to these models are needed to cover the specific details of IWW navigation.

Parts of the MEZ was demonstrated on an USV in a canal in Trondheim, Norway, and this shows that the principles can be further developed to cover all data needed by a complete mission.

In this paper, we only cover mission planning and execution data. In addition to this comes information that is needed by the ROC to facilitate its operation, for instance information about opening hours, contact details and physical dimensions of locks and bridges, contact details, time schedules and physical dimensions for port facilities, bunker stations and other infrastructure, and static information and contact details about the vessels. In addition, we also need to investigate more in how the definition of level of autonomy in the mission exchange data to cover the different modes of operations for IWW vessels will work out in real cases.

Acknowledgments. This paper presents the outcomes of research done within the framework of the project AUTOFLEX (AUTONomous small and FLEXible vessels) which received funding from the European Union Horizon Europe Programme under the Grant Agreement 101136257.

Reference

- [1] H. C. Burmeister, Ø. J. Rødseth, and T. Porathe, 'Autonomous Unmanned Merchant Vessel and its Contribution towards the e-Navigation Implementation: The MUNIN Perspective', in *International Journal of e-Navigation and Maritime Economy*, 2014, pp. 1–13.
- [2] ISO, *ISO/TS 23860:2022 Ships and marine technology — Vocabulary related to autonomous ship systems*, 2022. Accessed: Jun. 19, 2023. [Online]. Available: <https://www.iso.org/standard/77186.html>
- [3] IMO, 'Amendments to IMO instruments: upcoming and recent entry into force/effective dates'. Accessed: Jun. 20, 2025. [Online]. Available: <https://www.imo.org/en/About/Conventions/Pages/Amendments-to-IMO-instruments.aspx>
- [4] IMO, 'IMO Resolution A.893(21)', A.893(21), Nov. 1999. Accessed: Jun. 20, 2025. [Online]. Available: [https://www.wcdn.imo.org/localresources/en/KnowledgeCentre/IndexofIMOResolutions/AssemblyDocuments/A.893\(21\).pdf](https://www.wcdn.imo.org/localresources/en/KnowledgeCentre/IndexofIMOResolutions/AssemblyDocuments/A.893(21).pdf)
- [5] *Route plan exchange format - RTZ*. [Online]. Available: <https://cirm.org/rtz-xml-schemas>
- [6] A. Rydinger, 'MONALISA 2.0 – Activity 1.3 STM Voyage exchange format and architecture', MONALISA 2 0_D1.3.2, Dec. 2015.
- [7] H. C. Burmeister, T. Scheidweiler, M. Reimann, and C. Jahn, 'Assessing Safety Effects of Digitization with the European Maritime Simulator Network EMSN: The Sea Traffic Management Case', in *The International Journal on Marine Navigation and Safety of Sea Transportation*, 2020, pp. 91–96. doi: 10.12716/1001.14.01.10.
- [8] *IEC 63173-1:2021: Maritime navigation and radiocommunication equipment and systems - Data interfaces - Part 1: S-421 route plan based on S-100*. [Online]. Available: <https://webstore.iec.ch/en/publication/32931>
- [9] *S-421 Converter*. ECC. [Online]. Available: <https://s421creator.ecc.no/>
- [10] H. Dybvik, E. Veitch, and M. Steinert, 'EXPLORING CHALLENGES WITH DESIGNING AND DEVELOPING SHORE CONTROL CENTERS (SCC) FOR AUTONOMOUS SHIPS', *Proc. Des. Soc. Des. Conf.*, vol. 1, pp. 847–856, May 2020, doi: 10.1017/dsd.2020.131.
- [11] J. (Hans) van den Broek, J. R. (Jaco) Griffioen, and M. (Monique) van der Drift, 'Meaningful Human Control in Autonomous Shipping: An Overview', *IOP Conf. Ser. Mater. Sci. Eng.*, vol. 929, no. 1, p. 012008, Nov. 2020, doi: 10.1088/1757-899X/929/1/012008.
- [12] O. A. Alsos *et al.*, 'NTNU Shore Control Lab: Designing shore control centres in the age of autonomous ships', *J. Phys. Conf. Ser.*, vol. 2311, no. 1, p. 012030, Jul. 2022, doi: 10.1088/1742-6596/2311/1/012030.
- [13] E. Veitch, 'Designing for Land-based Control of Autonomous Vessels', Doctoral thesis, NTNU, 2023. Accessed: May 26, 2025. [Online]. Available: <https://ntnuopen.ntnu.no/ntnu-xmlui/handle/11250/3088574>
- [14] L. P. Perera, V. Ferrari, F. P. Santos, M. A. Hinostroza, and C. Guedes Soares, 'Experimental Evaluations on Ship Autonomous Navigation and Collision Avoidance by Intelligent Guidance', *IEEE J. Ocean. Eng.*, vol. 40, no. 2, pp. 374–387, Apr. 2015, doi: 10.1109/JOE.2014.2304793.
- [15] Y. Gu, J. C. Goez, M. Guajardo, and S. W. Wallace, 'Autonomous vessels: state of the art and potential opportunities in logistics', *Int. Trans. Oper. Res.*, vol. 28, no. 4, pp. 1706–1739, 2021, doi: 10.1111/itor.12785.
- [16] Ü. Öztürk, M. Akdağ, and T. Ayabakan, 'A review of path planning algorithms in maritime autonomous surface ships: Navigation safety perspective', *Ocean Eng.*, vol. 251, p. 111010, May 2022, doi: 10.1016/j.oceaneng.2022.111010.
- [17] Y. Qiao, J. Yin, W. Wang, F. Duarte, J. Yang, and C. Ratti, 'Survey of Deep Learning for Autonomous Surface Vehicles in Marine Environments', *IEEE Trans. Intell. Transp. Syst.*, vol. 24, no. 4, pp. 3678–3701, Apr. 2023, doi: 10.1109/TITS.2023.3235911.
- [18] T. Stach, Y. Kinkel, M. Constapel, and H.-C. Burmeister, 'Maritime Anomaly Detection for Vessel Traffic Services: A Survey', in *J. Mar. Sci. Eng.*, 2023. doi: <https://doi.org/10.3390/jmse11061174>.
- [19] K. Wolsing, L. Bauer, and K. Wehrle, 'Anomaly Detection in Maritime AIS Tracks: A Review of Recent Approaches', in *J. Mar. Sci. Eng.*, 2022. doi: <https://doi.org/10.3390/jmse10010112>.
- [20] G. Kia and S. Van Staeyen, 'Barge Use Case', D4.1. [Online]. Available: https://www.5gblueprint.eu/wp-content/uploads/sites/62/2024/01/D4.1_Barge-use-case_V1.2_15.12.2023.pdf
- [21] 'SeaNext', [Online]. Available: <https://business.esa.int/projects/seanext>
- [22] A. Atyabi, S. MahmoudZadeh, and S. Nefti-Meziani, 'Current advancements on autonomous mission planning and management systems: An AUV and UAV perspective', *Annu. Rev. Control*, vol. 46, pp. 196–215, Jan. 2018, doi: 10.1016/j.arcontrol.2018.07.002.
- [23] F. Thompson and D. Guihen, 'Review of mission planning for autonomous marine vehicle fleets', *J. Field Robot.*, vol. 36, no. 2, pp. 333–354, 2019, doi: 10.1002/rob.21819.
- [24] F. Thompson and R. Galeazzi, 'Robust mission planning for Autonomous Marine Vehicle fleets', *Robot. Auton. Syst.*, vol. 124, p. 103404, Feb. 2020, doi: 10.1016/j.robot.2019.103404.
- [25] M. A. Hinostroza and A. M. Lekkass, 'A Rudimentary Mission Planning System for Marine Autonomous Surface Ships', *IFAC-Pap.*, vol. 55, no. 31, pp. 196–203, Jan. 2022, doi: 10.1016/j.ifacol.2022.10.431.

- [26] M. A. Hinostroza and A. M. Lekkas, 'Temporal mission planning for autonomous ships: Design and integration with guidance, navigation and control', *Ocean Eng.*, vol. 297, p. 117104, Apr. 2024, doi: 10.1016/j.oceaneng.2024.117104.
- [27] *IENC Feature Catalogue*, Apr. 21, 2021. [Online]. Available: https://www.cesni.eu/wp-content/uploads/2023/05/Appendices-Part1-IECDIS_BD.pdf
- [28] *INLAND ELECTRONIC NAVIGATIONAL CHART PRODUCT SPECIFICATION, Draft IEHG Publication S-401, Annex A Data Classification and Encoding Guide*.
- [29] *Autoremove systems*. Accessed: Jun. 22, 2025. [Online]. Available: <https://www.dnv.com/maritime/autonomous-remotely-operated-ships/autoremove-systems/>
- [30] *Explanatory note related to the international definition of levels of automation in inland navigation*, 2022.
- [31] '<https://autoflex-vessel.eu/>'.
- [32] 'Explanatory note related to the international definition of levels of automation in inland navigation'. CCNR, 2022.
- [33] *CEVNI European Code for Inland Waterways*, 2021.
- [34] *S-421 Route Exchange*. [Online]. Available: <https://cirm.org/s-421>
- [35] 'Encoding Guide for Inland ENC (draft)' in Inland ENC Harmonization Group.
- [36] *IEHG INLAND ELECTRONIC NAVIGATIONAL CHART PRODUCT SPECIFICATION Draft*, Sep. 2024.
- [37] *Bayplan/stowage plan occupied and empty locations message*. [Online]. Available: https://service.unece.org/trade/untddid/d17a/trmd/baplie_c.htm
- [38] *IMO Compendium on Facilitation and Electronic Business*. [Online]. Available: <https://imocompendium.imo.org/public/IMO-Compendium/Current/index.htm>
- [39] *IHO Marine Harbour Infrastructure (MHI) Product Specification*, S-131, Mar. 2023. [Online]. Available: https://iho.int/uploads/user/pubs/Drafts/S-131%20Marine%20Harbour%20Infrastructure%201_0_0%20Product%20Specification.pdf
- [40] Maritime Robotics, 'The Otter X', Maritime Robotics. Accessed: Jun. 19, 2025. [Online]. Available: <https://www.maritimerobotics.com/otter-x>