The Role of Independent Engineers – From the Project Idea to Real World Evaluation of PV Battery Systems



Matthias Vetter

Fraunhofer Institute for
Solar Energy Systems ISE

ees Europe Conference

Munich, 30th of May 2017

Agenda

- Tasks of independent engineers
- Motivation and applications of larger PV battery systems
- Quality assurance for PV power plants with battery storage
- Quality assurance for PV battery systems in commercial applications and mini-grids
- Example of a commercial PV battery system
- Example of a district storage
- Examples of mini-grid applications
- Services towards certification
- Conclusions



Tasks of independent engineers

Along the whole project life time

Planning phase

- Evaluation of project idea
- Potential analysis
- Definition of project requirements
- Identification of challenges
- Identification of risks
- Identification of chances and benefits

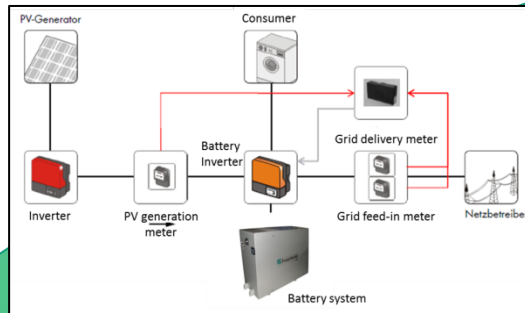

Development phase

- Simulation based system design and optimization
- Elaboration of specifications
- Support in component selection and system setup
- Laboratory tests
- Consultancy in product selection
- Neutral contact point for financial and insurance sector
- Consultancy for construction



Implementation phase

- Commissioning tests
- Ongoing quality monitoring
- Identification of component and system failures
- Identification of optimization potential
- Frequent reporting
- Support in Decommissioning
- Consultancy in terms of recycling

Motivation and applications of larger photovoltaic battery systems

- Integration of battery storage in PV power plants
 - Feeding-in of PV power according to the needs of the grid
 - But: Battery storage increases the LCOE
- Integration of battery storage in commercial grid connected PV applications
 - Increasing PV self consumption and reducing electricity bill
 - But: Reasonable usage depends on specific boundary conditions and system performance
- Integration of battery storage in hybrid PV Diesel mini-grids
 - Increasing the solar share and decreasing Diesel cost
 - But: Economic benefits depend on project life-time and proper system design



Quality assurance for photovoltaic power plants with battery storage

From project planning to system monitoring

TECHNICAL ADVICE ON STORAGE SELECTION
AND DIMENSIONING

CHARACTERIZATION OF BATTERY SYSTEMS

YIELD PREDICTION FOR THE OVERALL SYSTEM

SYSTEM TESTING

QUALITY MONITORING



Quality assurance for photovoltaic power plants with battery storage

From project planning to system monitoring

TECHNICAL ADVICE ON STORAGE SELECTION AND DIMENSIONING

CHARACTERIZATION OF BATT

YIELD PREDICTION FOR TH

SYSTEM TESTING

QUALITY MONITOR

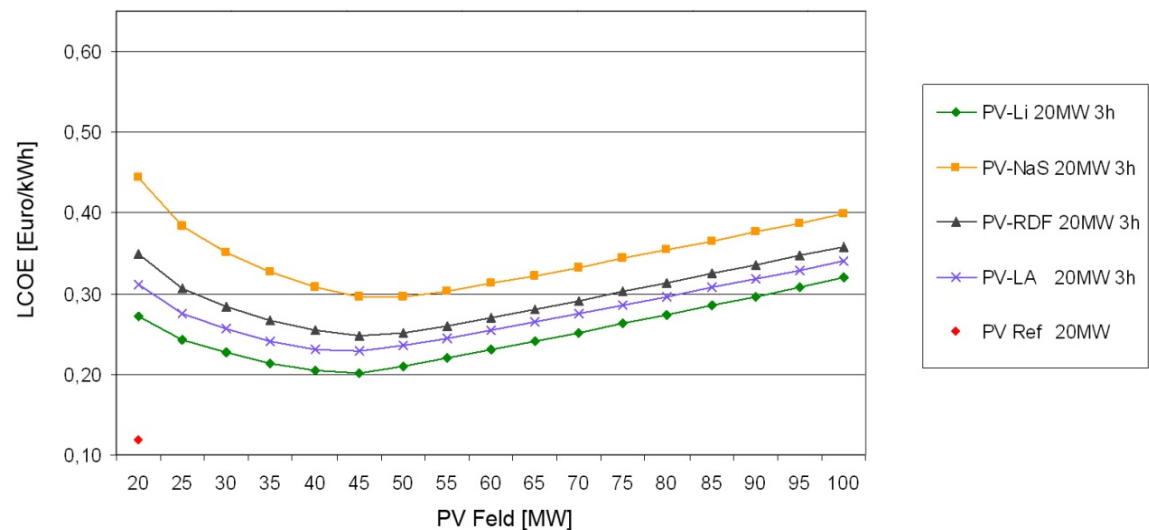
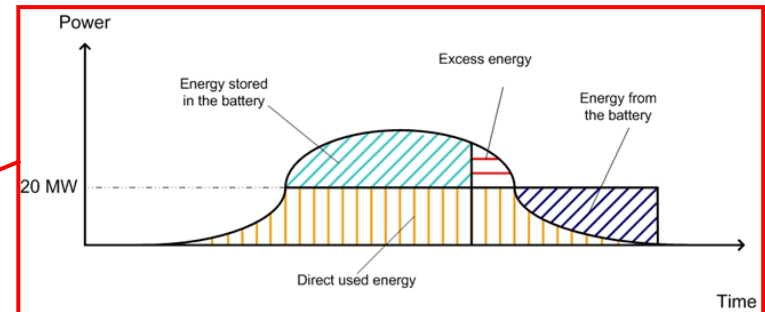

Quality assurance for photovoltaic power plants with battery storage

From project planning to system monitoring

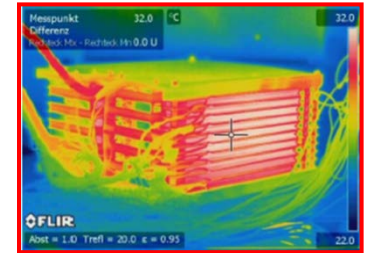

TECHNICAL ADVICE ON STORAGE SELECTION AND DIMENSIONING

CHARACTERIZATION OF BATTERY SYSTEMS

YIELD PREDICTION

SYSTEM T...

QUALITY

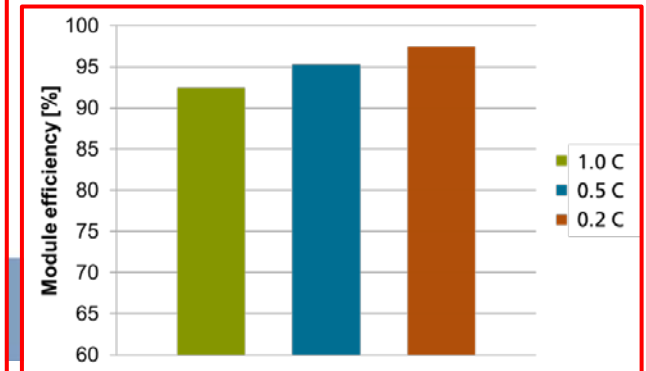
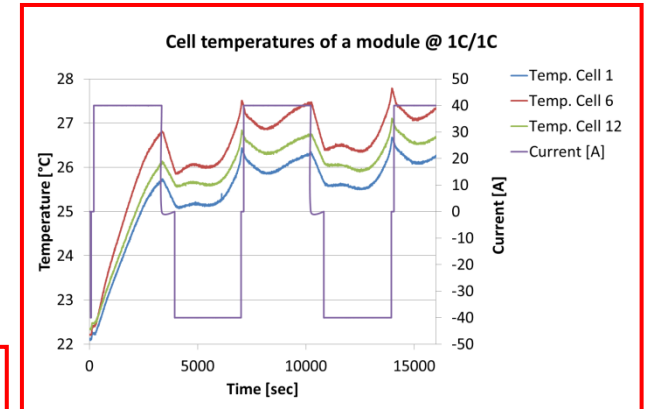
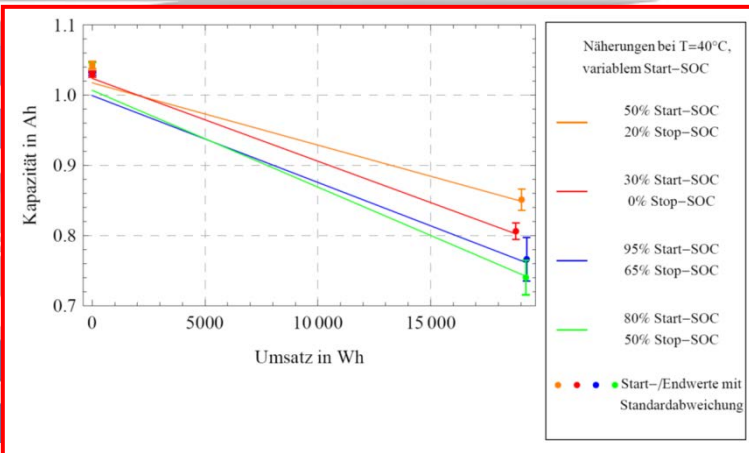

Quality assurance for photovoltaic power plants with battery storage

From project planning to system monitoring

TECHNICAL ADVICE ON STORAGE SELECTION AND DIMENSIONING

CHARACTERIZATION OF BATTERY SYSTEMS

YIELD PREDICTION FOR THE OVERALL SYSTEM

SYSTEM TESTING

QUALITY MONITORING

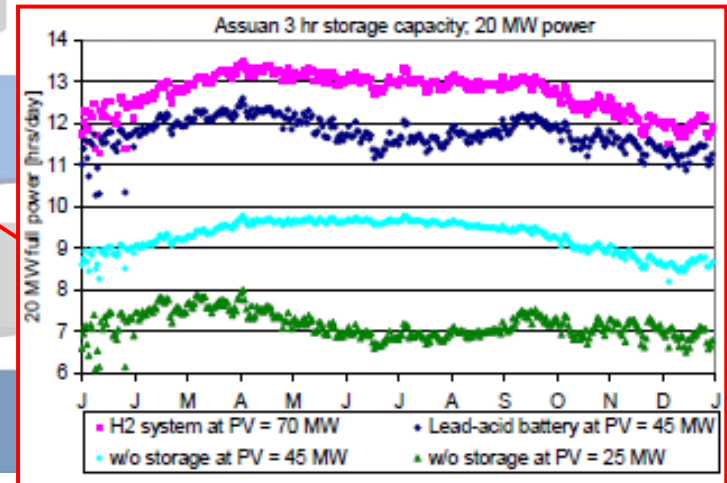
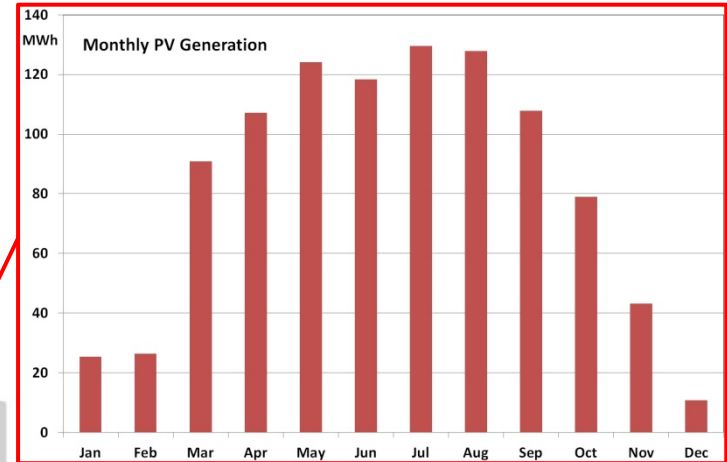

Quality assurance for photovoltaic power plants with battery storage

From project planning to system monitoring

TECHNICAL ADVICE ON STORAGE SELECTION
AND DIMENSIONING

CHARACTERIZATION OF BATTERY SYSTEMS

YIELD PREDICTION FOR THE OVERALL SYSTEM

SYSTEM TESTING

QUALITY MONITORING

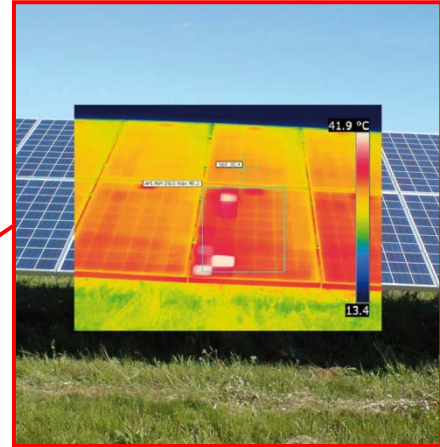

Quality assurance for photovoltaic battery systems in commercial applications and mini-grids

From project planning to system monitoring

TECHNICAL ADVICE ON STORAGE SELECTION AND DIMENSIONING

CHARACTERIZATION OF BATTERY SYSTEMS

YIELD PREDICTION FOR THE OVERALL SYSTEM

SYSTEM TESTING

QUALITY MONITORING

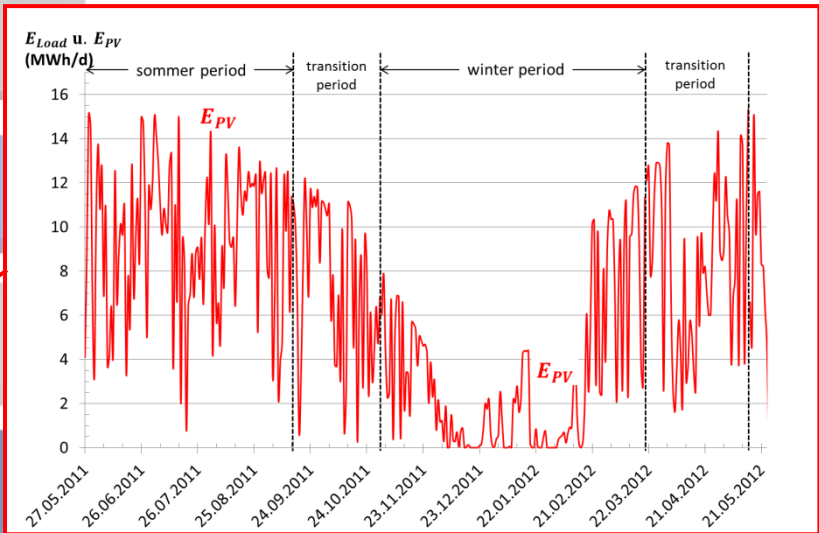
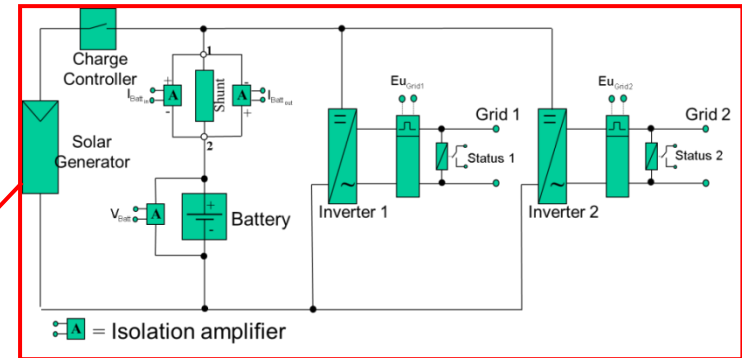

Quality assurance for photovoltaic battery systems in commercial applications and mini-grids

From project planning to system monitoring

ANALYSES OF LOAD PROFILES

SYSTEM DIMENSIONING & COMPONENT SELECTION

CHARACTERIZATION OF SYSTEM COMPONENTS

YIELD PREDICTION FOR THE PV SUBSYSTEM

SYSTEM TESTING

QUALITY MONITORING



Example: Commercial PV battery system

Analysis of load profile and PV generation profile

Load (bakery):

- Consumption: 335 MWh/a
- Max. power: 118 kW

PV example:

- Size: 150 kWp
- Production: 135 MWh

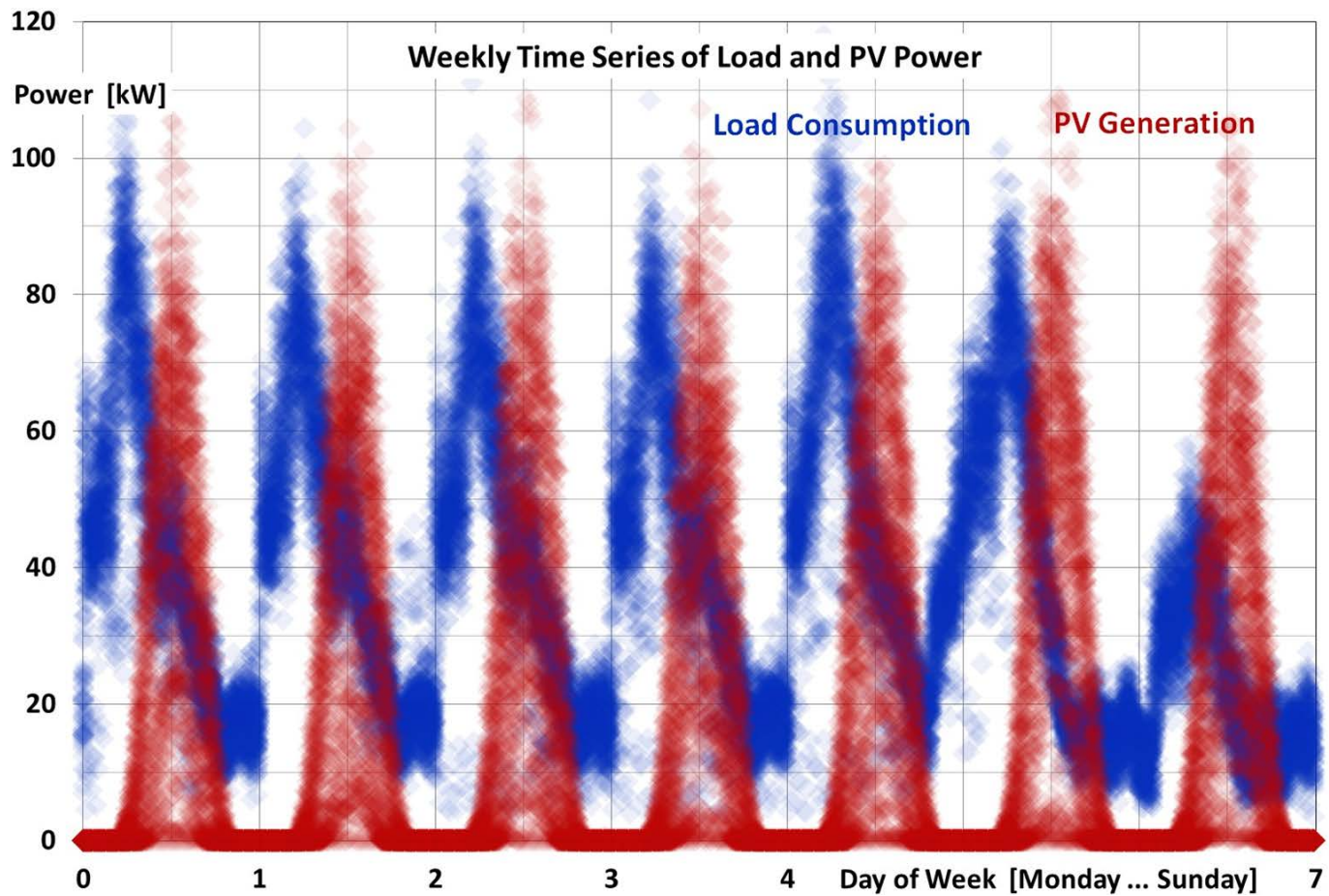

Example: Commercial PV battery system

Simulation based system analysis and design

Load (bakery):

- Consumption: 335 MWh/a
- Max. power: 118 kW

Integration of a PV system and a lithium-ion battery storage:

- Variation of PV system size
- Variation of battery storage size

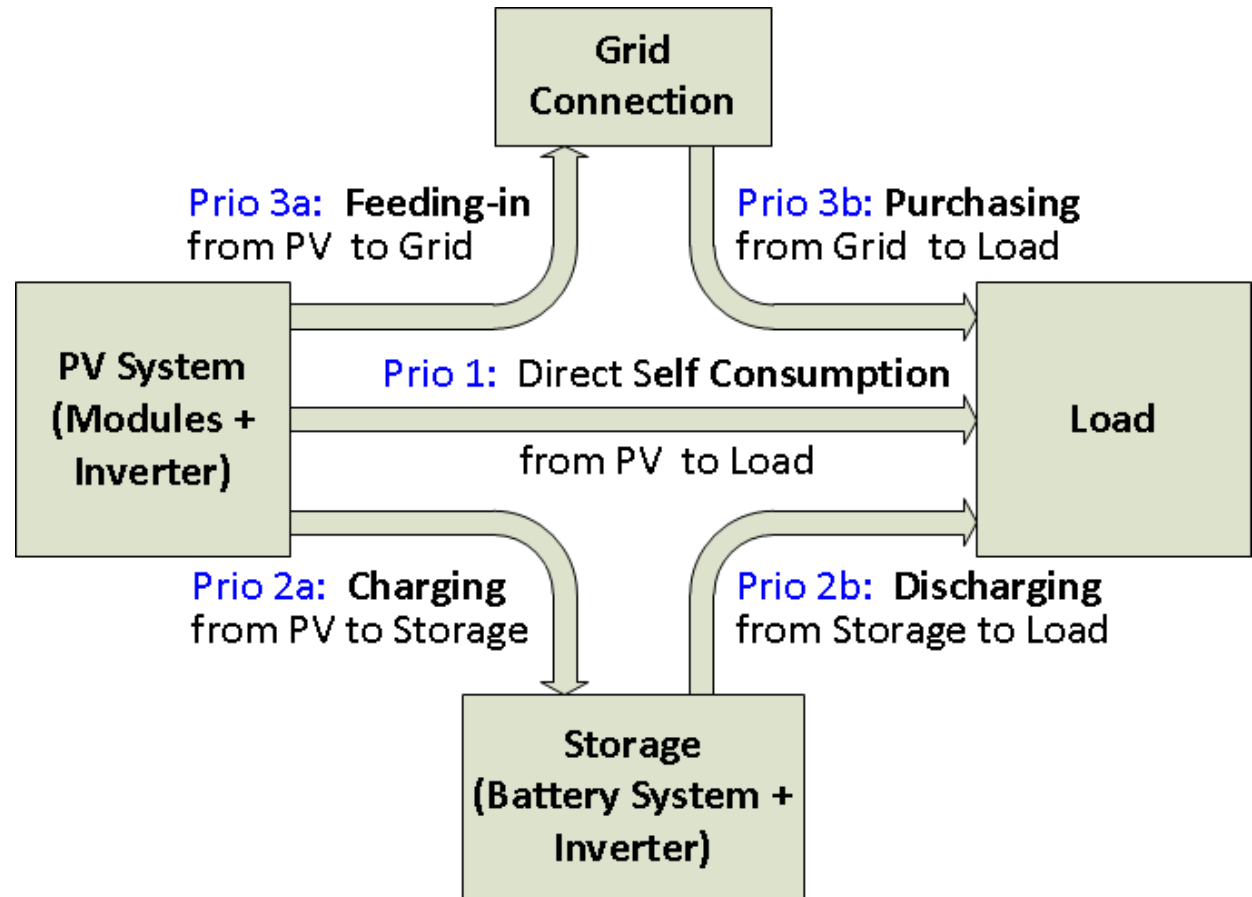

Example: Commercial PV battery system

Simulation based system analysis and design

Levelized cost of energy

Main parameters:

- PV system: 840 €/kWp
- Battery system: 600 €/kWh
- Battery inverter: 215 €/kW
- Interest rate: 3 %/a

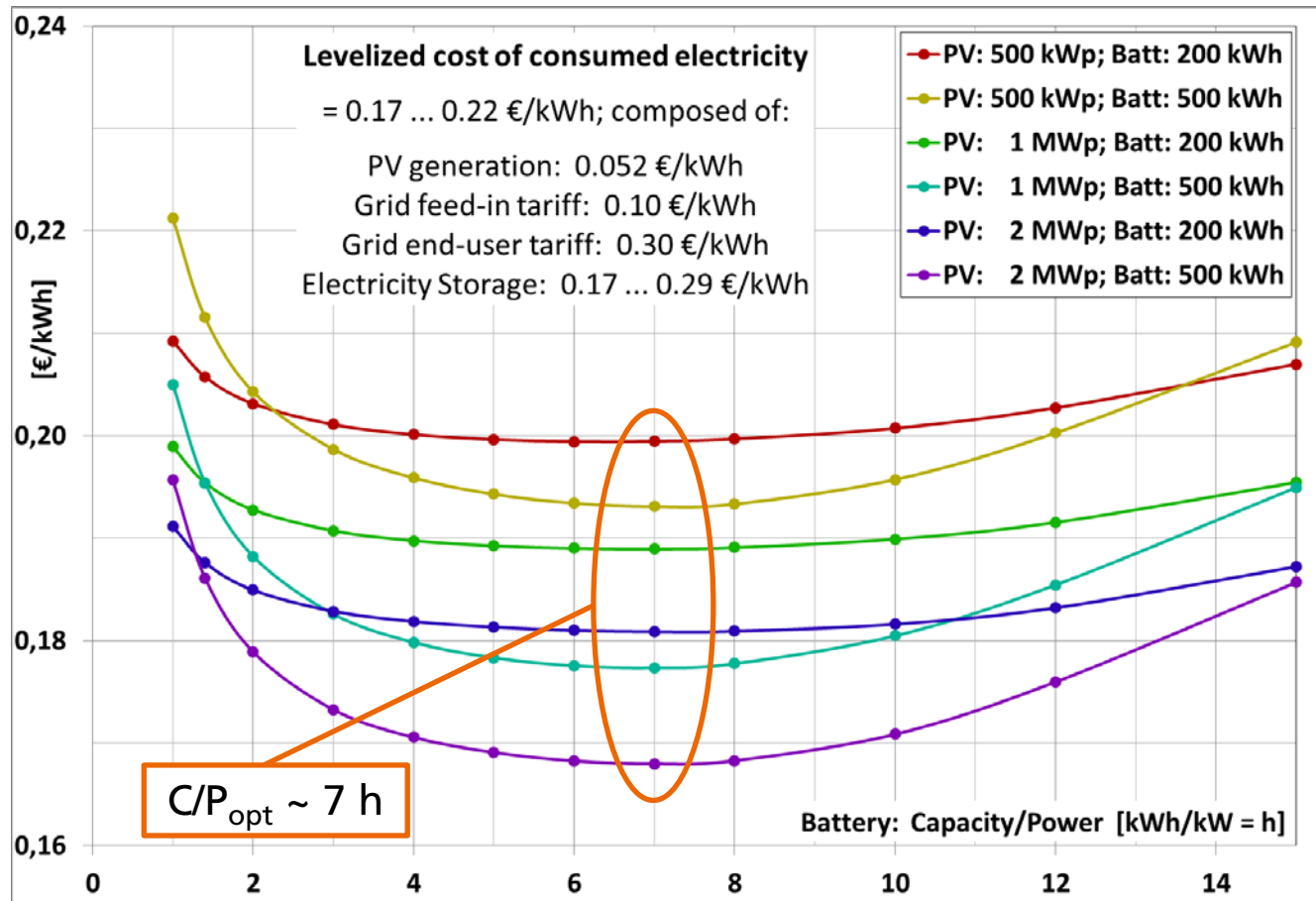

Example: Commercial PV battery system

Simulation based system analysis and design

Levelized cost of electricity storage

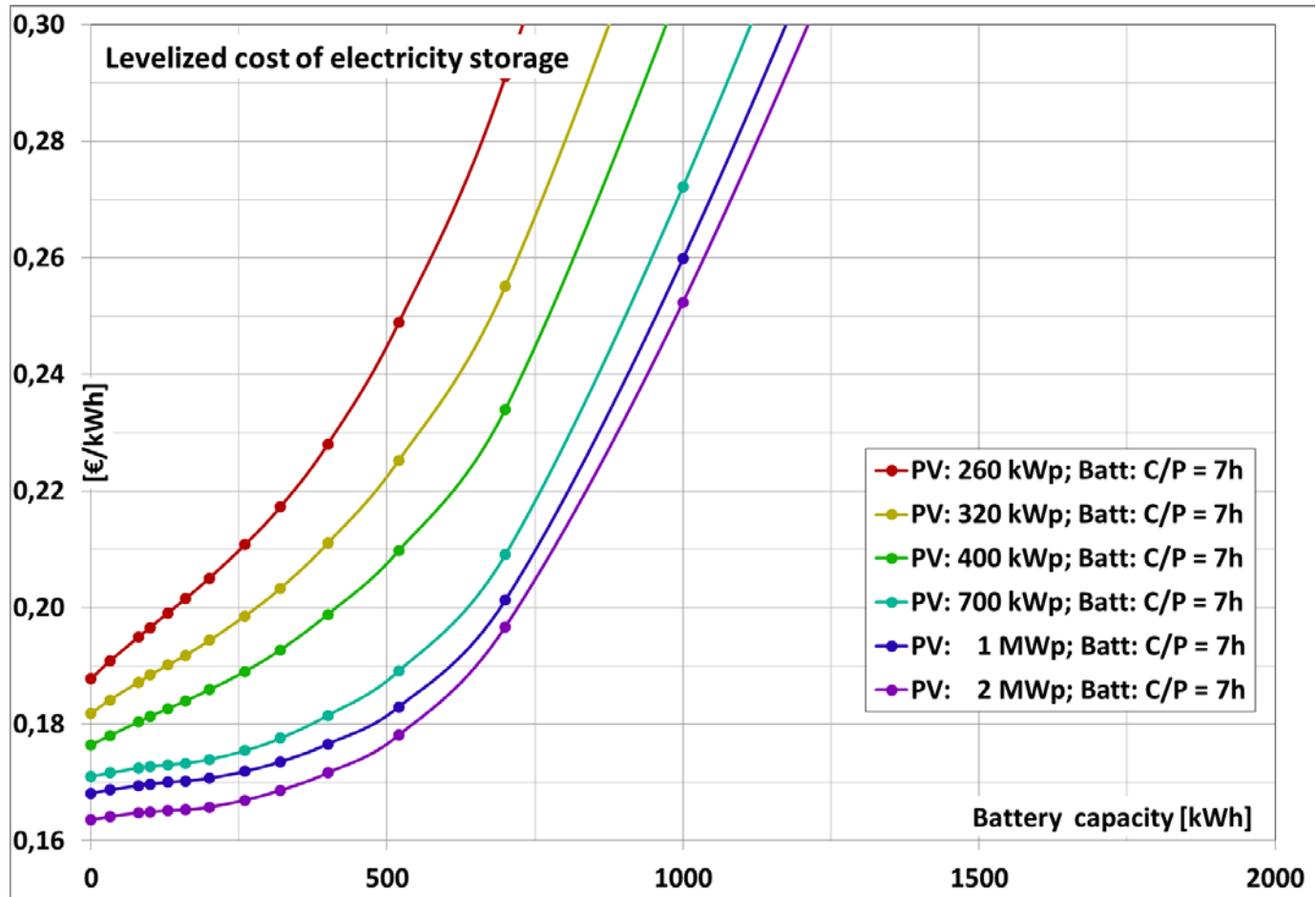

Example: Commercial PV battery system

Simulation based system analysis and design

Levelized cost of consumed electricity

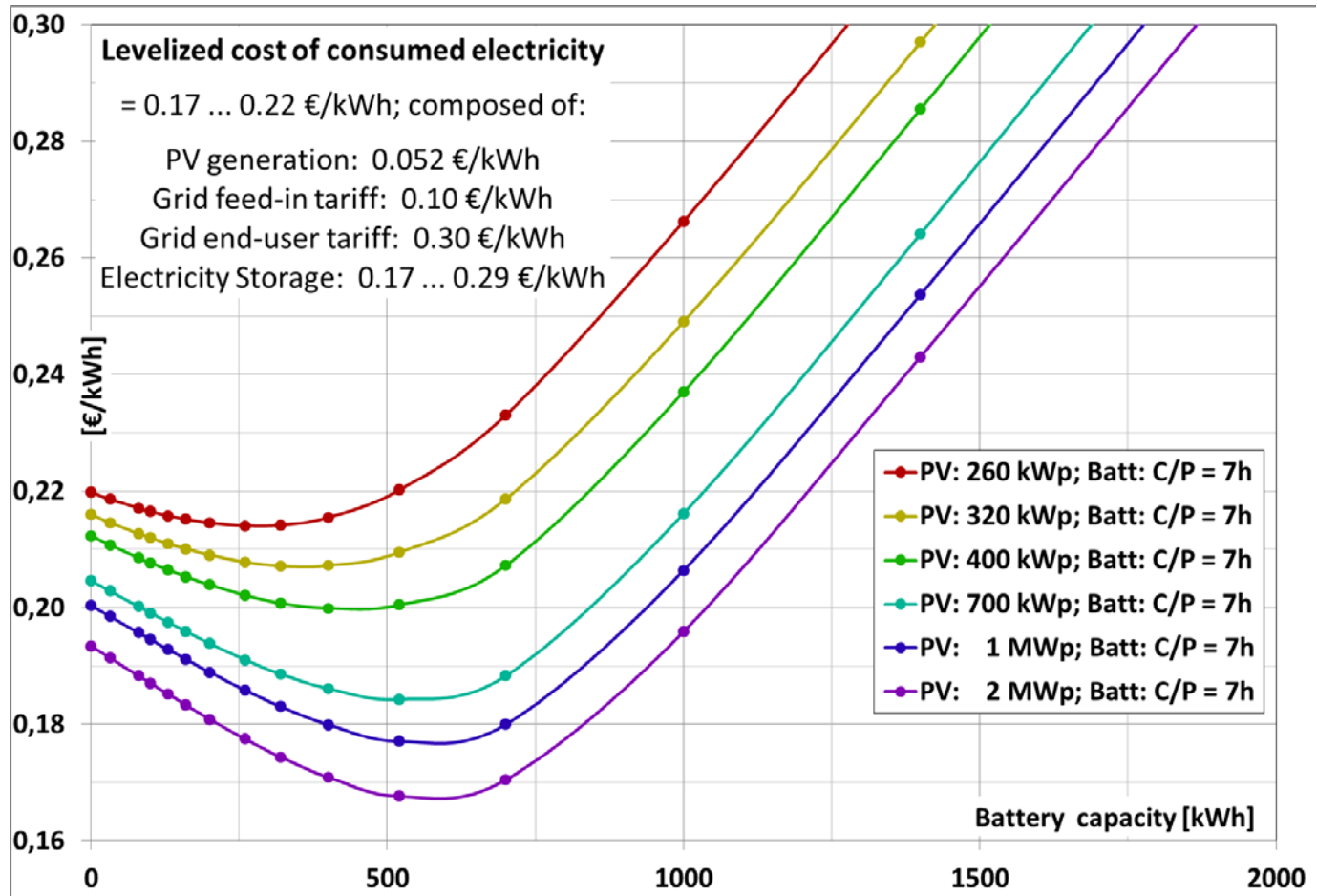

Example: Commercial PV battery system

Simulation based system analysis and design

Battery storage: Equivalent full cycles as a function of usable capacity and power

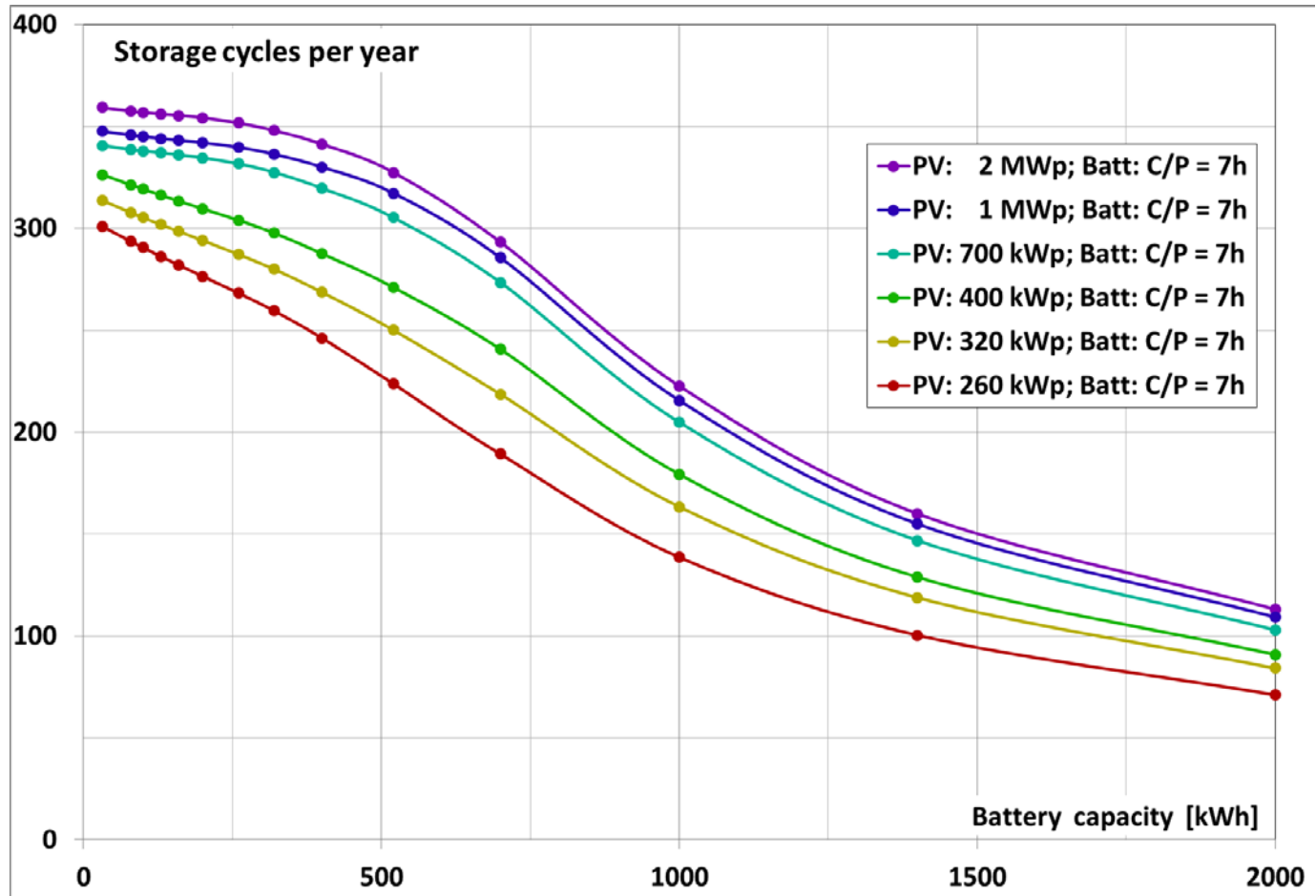

Example: Commercial PV battery system

Simulation based system analysis and design

Battery storage: Aging as a function of usable storage capacity and PV power

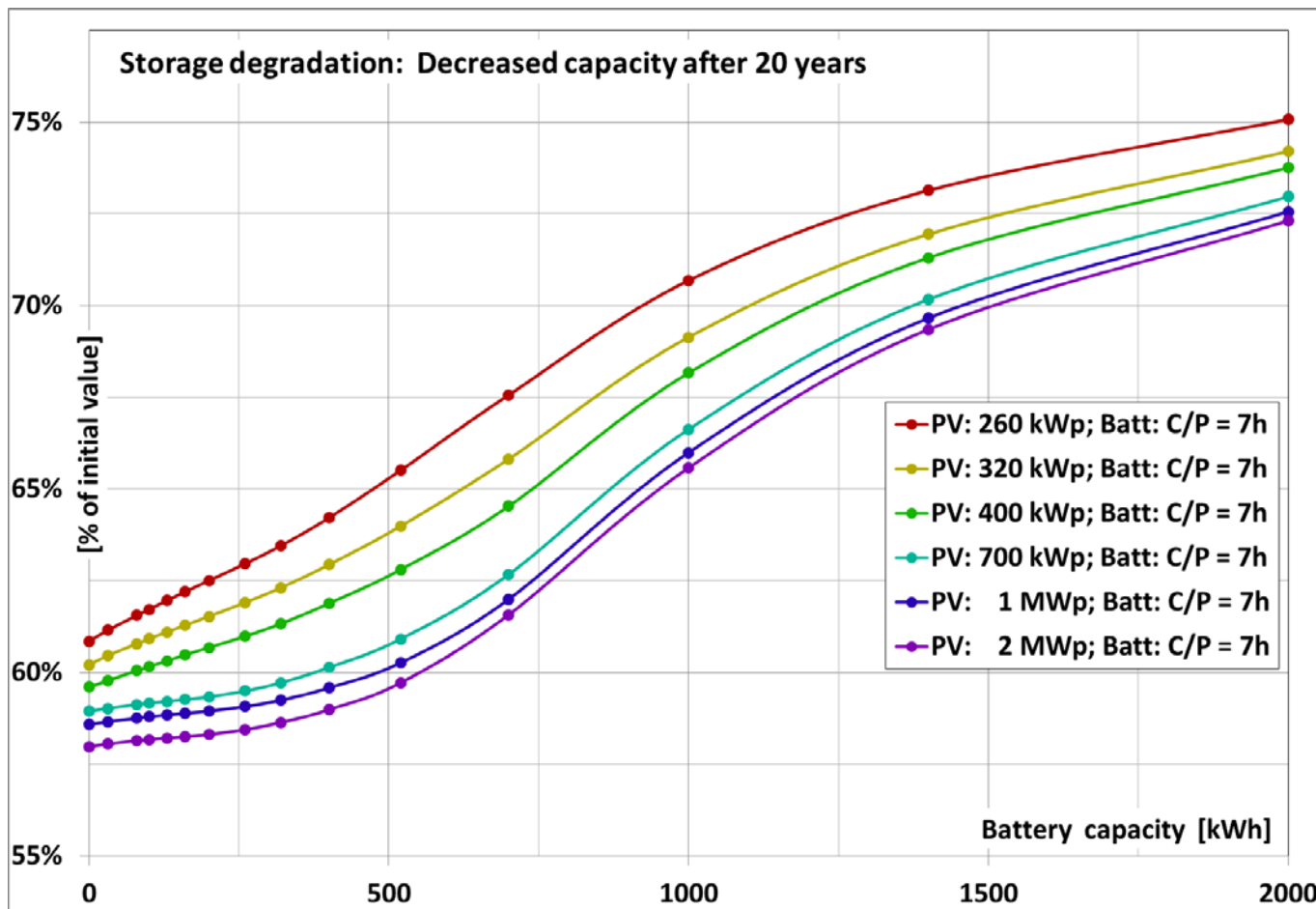

Example: Commercial PV battery system

Simulation based system analysis and design

Battery storage: Annual average storage efficiencies

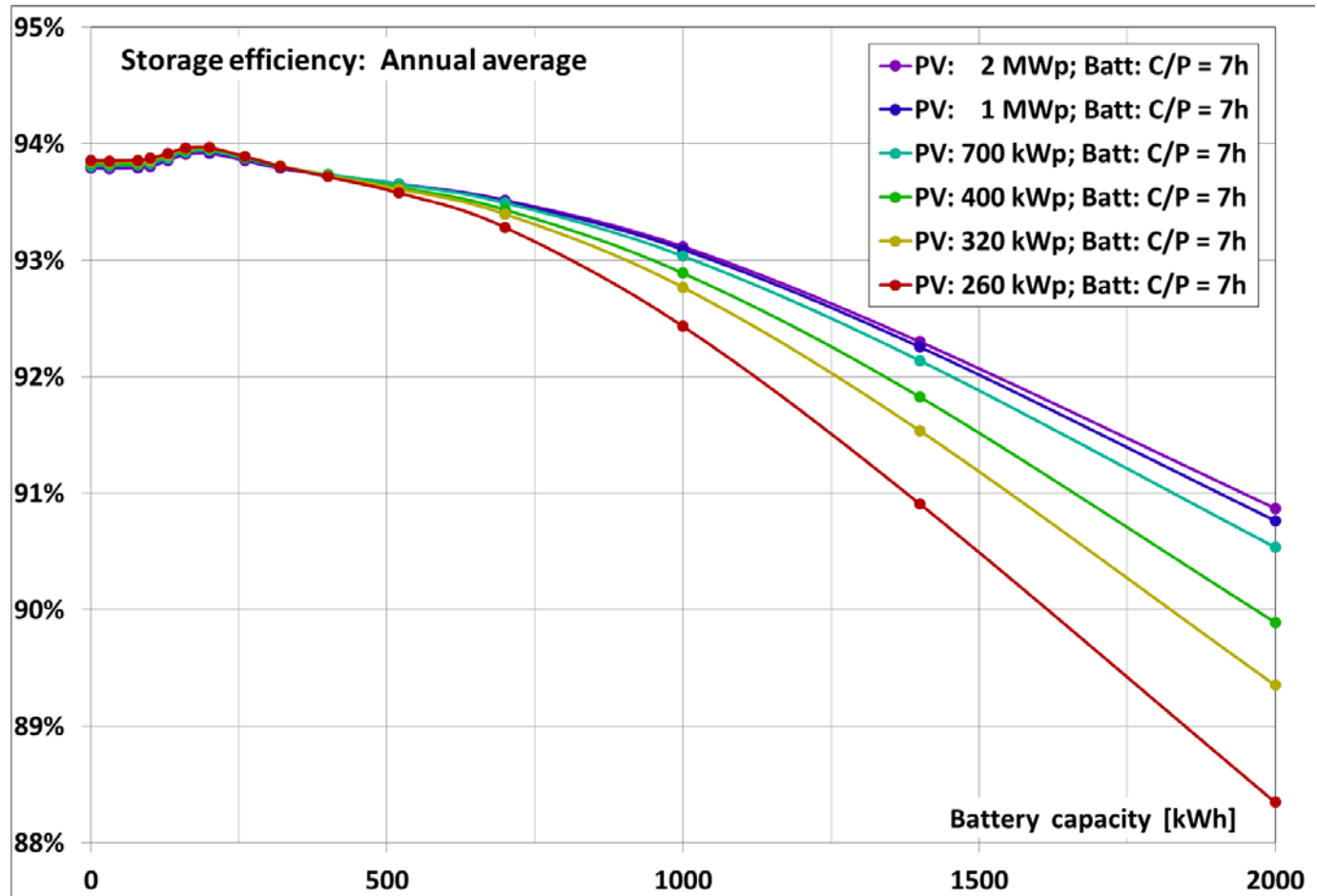

Example: District storage system – “Weinsberg”

Simulation based system design

Optimization criteria:

Minimization of grid dependency –

Physically not only accumulated

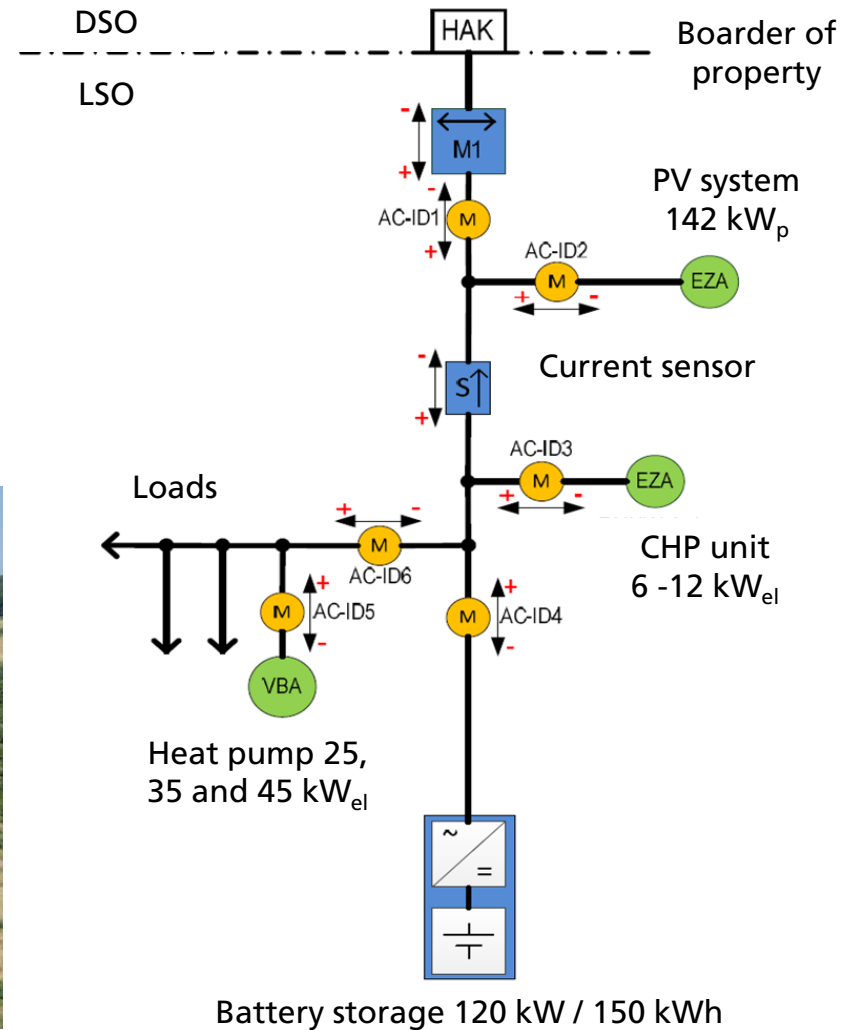

Example: District storage system – “Weinsberg”

Monitoring: Accumulated annual electrical energies

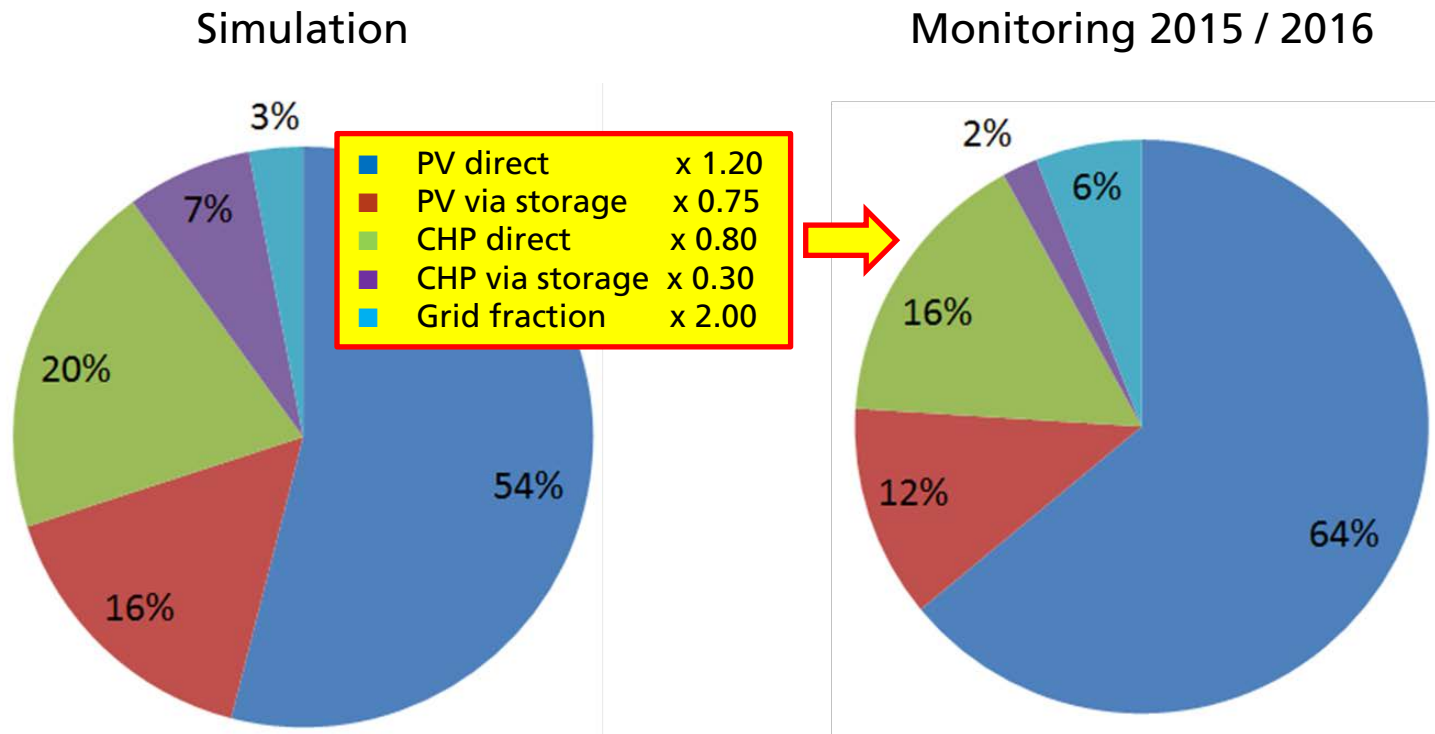

Reasons for differences:

- Problems with air conditioning → To high temperatures in operation room → Shut-down of CHP unit and battery inverter
- Necessary maintenance interval of CHP unit in winter (!)
- End-users do not behave 100 % as predicted (!)

Example: District storage system – “Weinsberg”

Monitoring: Analysis of storage operation

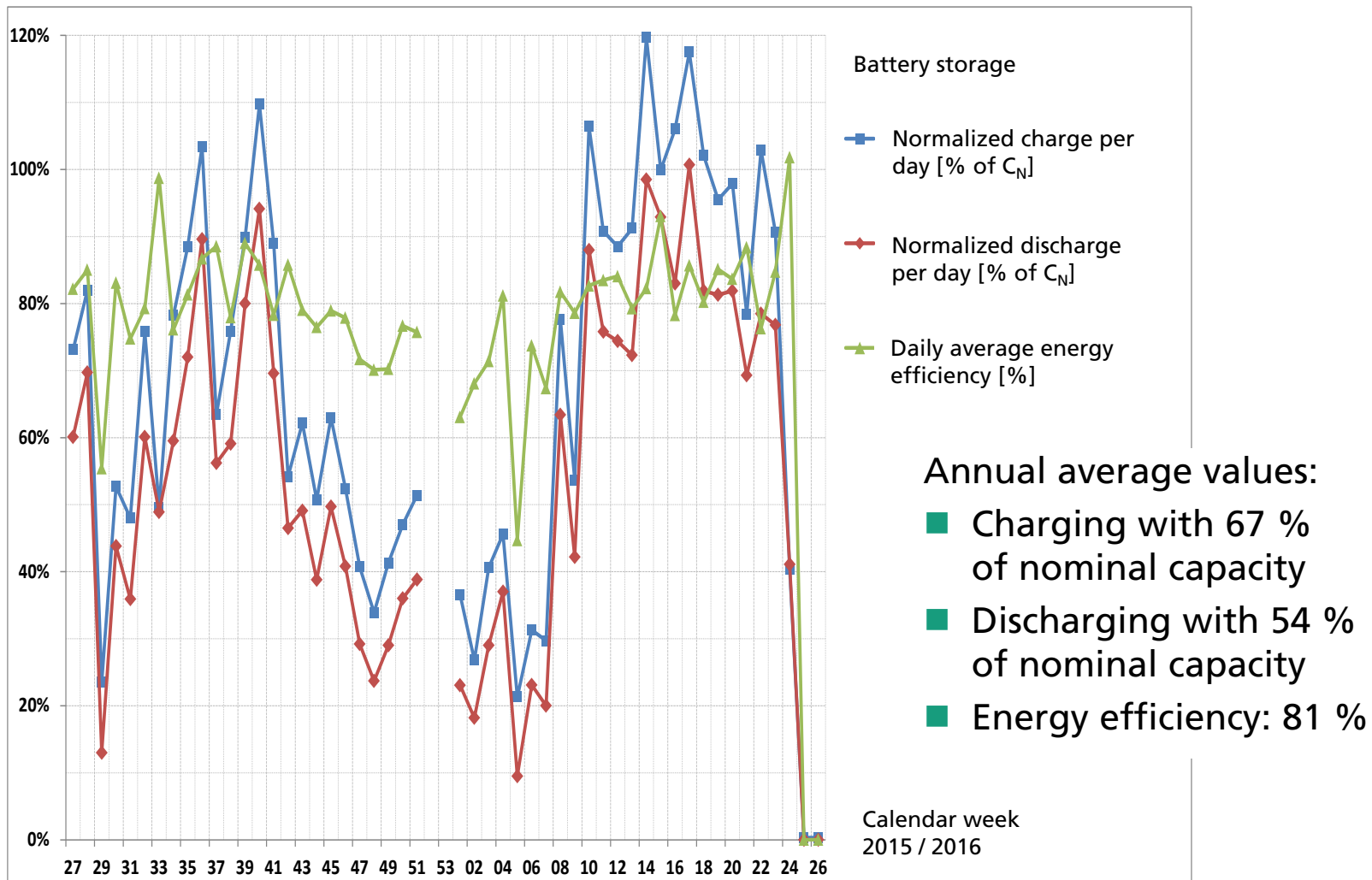

Example: PV mini-grids without storage

Simulation based system analysis and design



- 3 cases with varying load profiles
- Diesel consumption: Saturation at an application specific PV system size

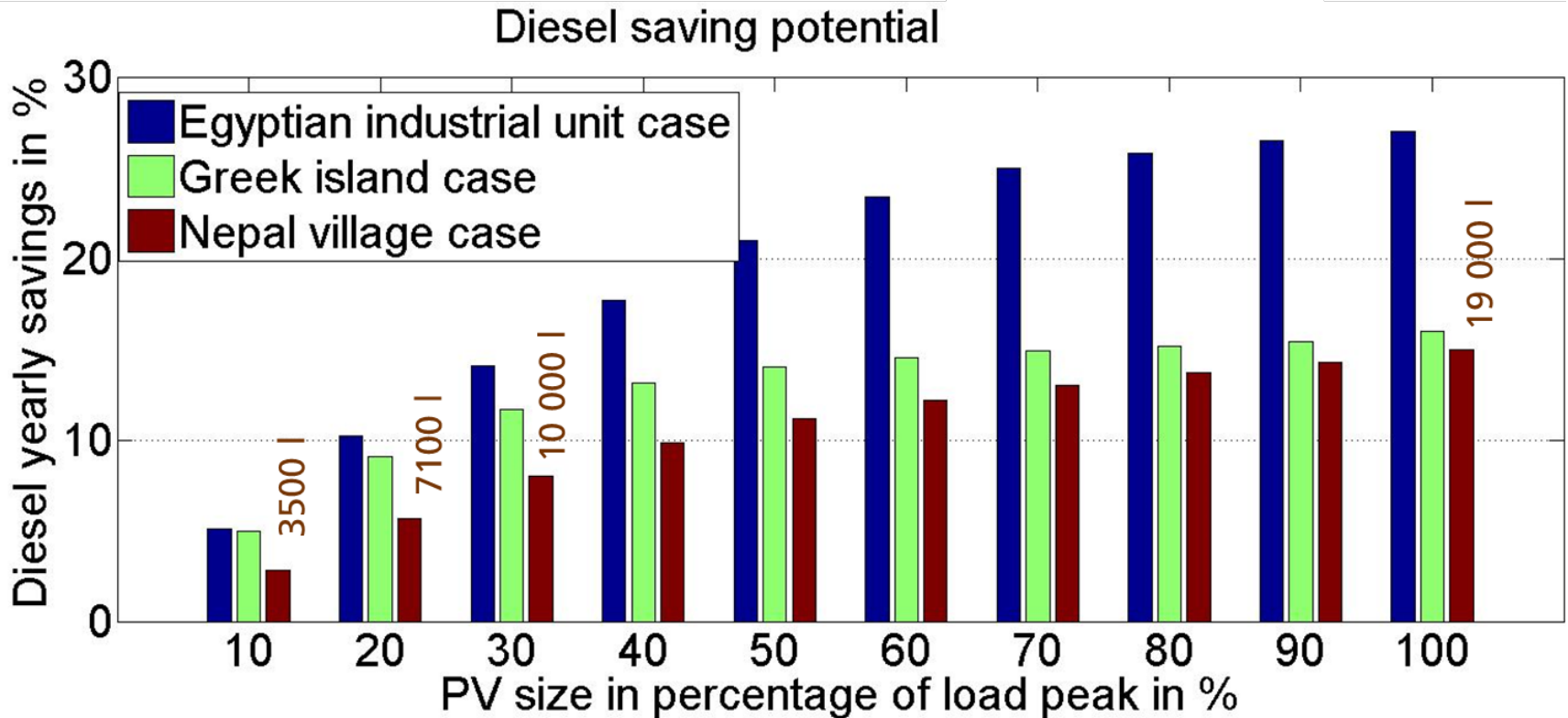

Example: PV mini-grids without storage

Simulation based system analysis and design

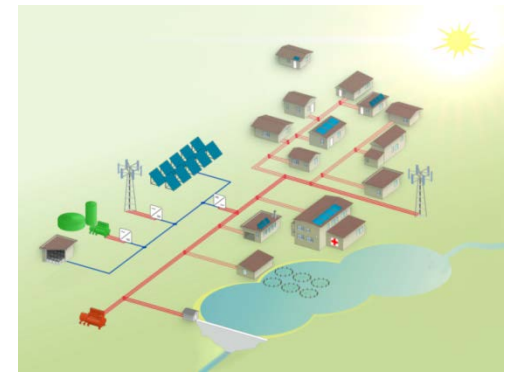

■ Example Uganda

■ Load:

- Peak load: 200 kW
- Annual consumpt.: 574 MWh

■ PV Diesel hybrid system:

- PV system (incl. power electronics): 1.5 Euro/Wp
- Battery system: 220 Euro/kWh
- Diesel: Invest 273 \$/kW; Fuel 1\$/l; Maintenance: 0.7 \$/h

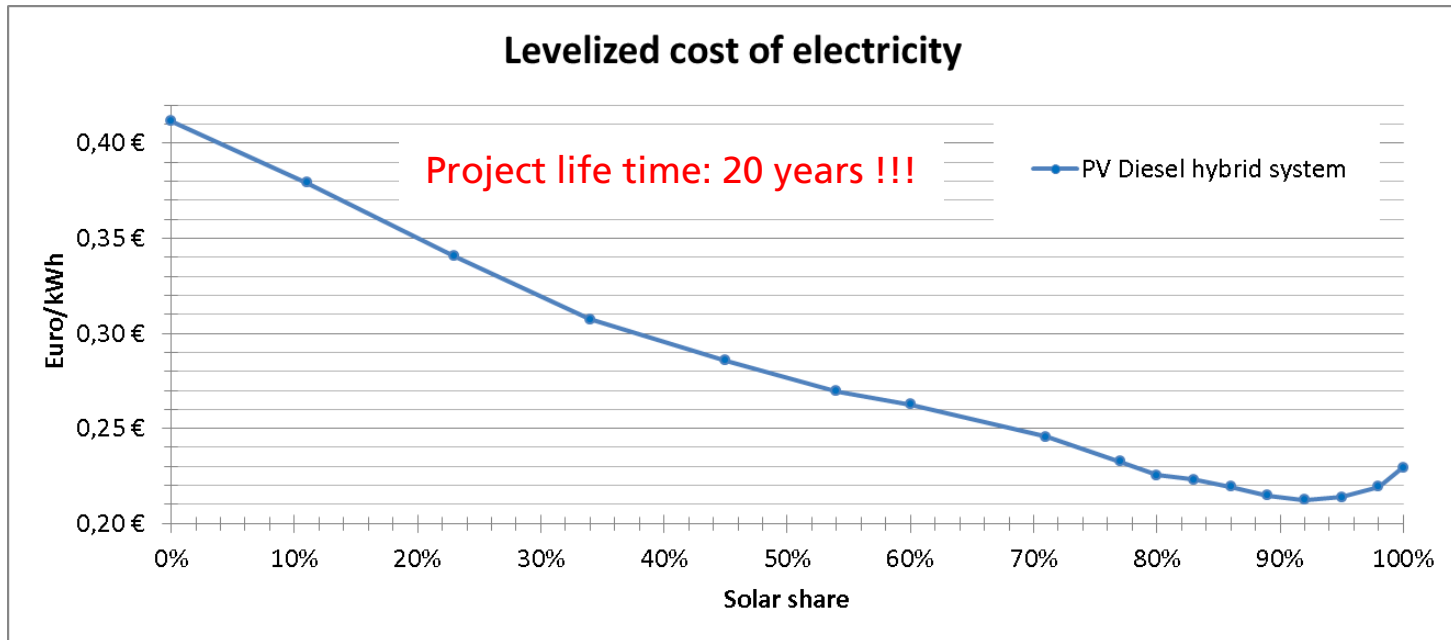

Services towards certification

From product development to project implementation

Strategic partnership of Fraunhofer ISE and VDE Renewables



Conclusions

- Integration of battery storage in PV power plants, commercial PV systems and hybrid PV mini-grids requires several steps of **quality assurance**:
 - From detailed load profile analyses to application specific system design and yield prediction
 - From characterization of components in the laboratory to system testing in the field and quality monitoring of the entire power plant
- Detailed **simulation based system analysis**:
 - Enables an “early” identification of application specific operating conditions of a battery storage
 - Enables life time predictions and determination of levelized cost of energy storage and levelized cost of consumed energy by using aging models
 - Enables an application specific optimization of the entire system design
 - Enables an application specific optimization of the operating control strategies
- **Monitoring** of battery storage systems:
 - Very important as no long-term field experience exists with new technologies
 - Enables an early identification of component and system failures
 - Enables a verification of the system design and an early identification of optimization potential (component and system level)

Thanks for your attention !!!



Fraunhofer Institute for Solar Energy Systems ISE

Dr. Matthias Vetter

www.ise.fraunhofer.de
matthias.vetter@ise.fraunhofer.de