

---

# Heat management of decentralized adiabatic compressed air energy storage

IRES III

Parallel session C:

Combining thermal energy storage and power generation

Berlin, 24.11.2008

**Daniel Wolf**

---



**Fraunhofer**

Institut

Umwelt-, Sicherheits-,

Energietechnik UMSICHT

# Content

---

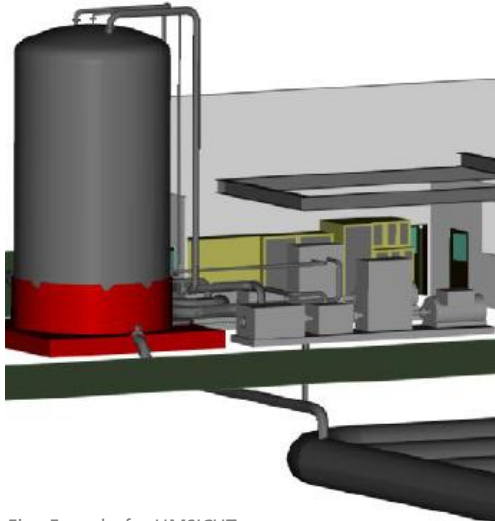

Fig.: Fraunhofer UMSICHT

- (1) Basic CAES concepts
- (2) Excess heat in CAES systems
- (3) Heat management solutions

# Diabatic Compressed Air Energy Storage

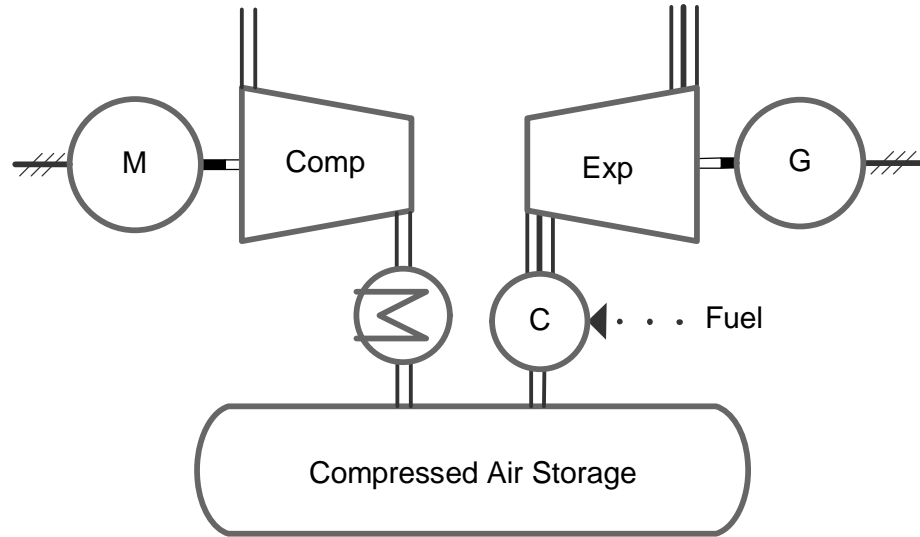
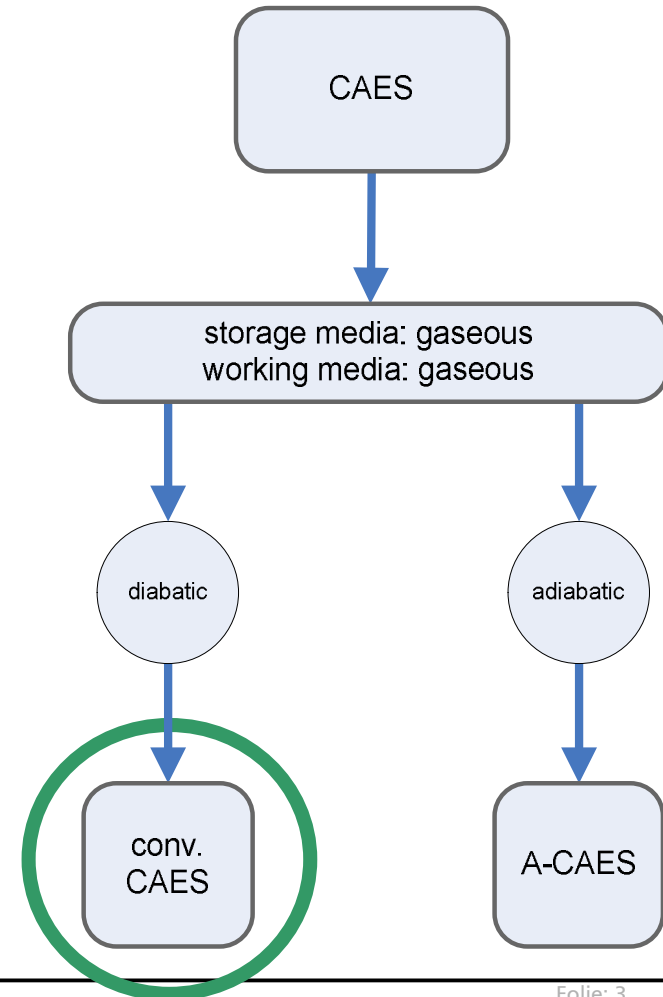

Fig.: Fraunhofer UMSICHT



## Diabatic CAES

- + wide output power control range
- + Lower spec. investment cost
- Lower cycle efficiency of up to 0.55
- No real storage

# Adiabatic Compressed Air Energy Storage

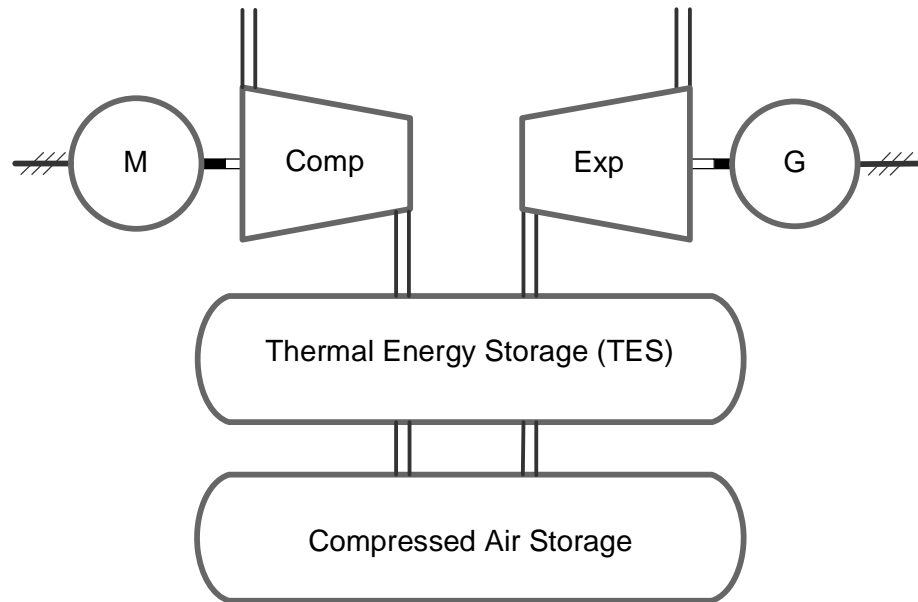
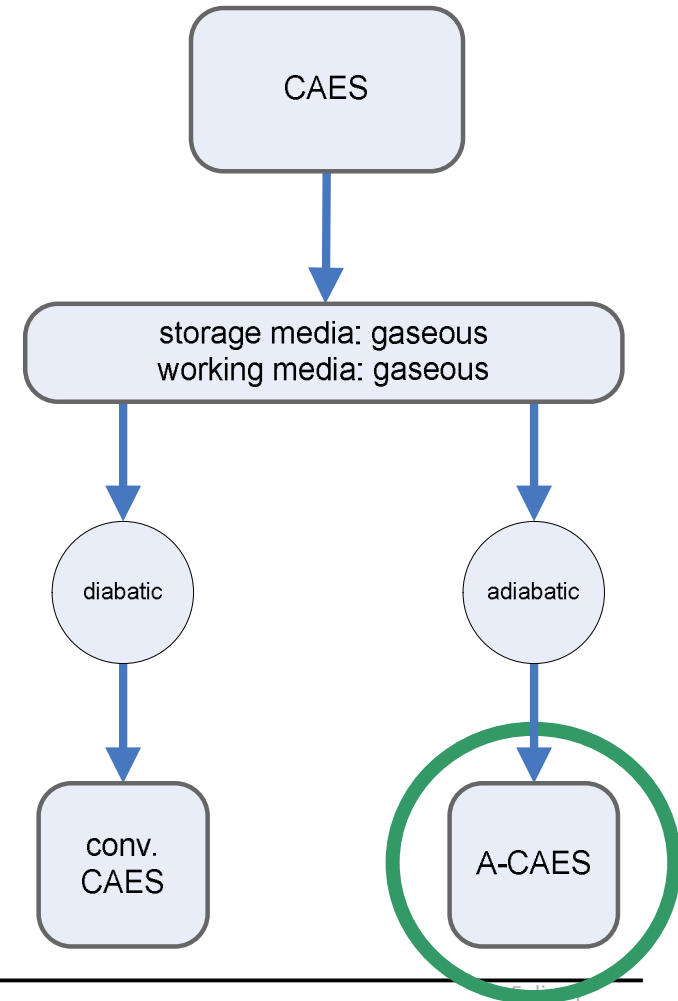

Fig.: Fraunhofer UMSICHT



## Adiabatic CAES

- + Zero emission
- + High cycle efficiency of up to 0.7
- + Independent of fuel price volatility
- Smaller output power control range
- Higher spec. investment cost

# A-CAES plant layout

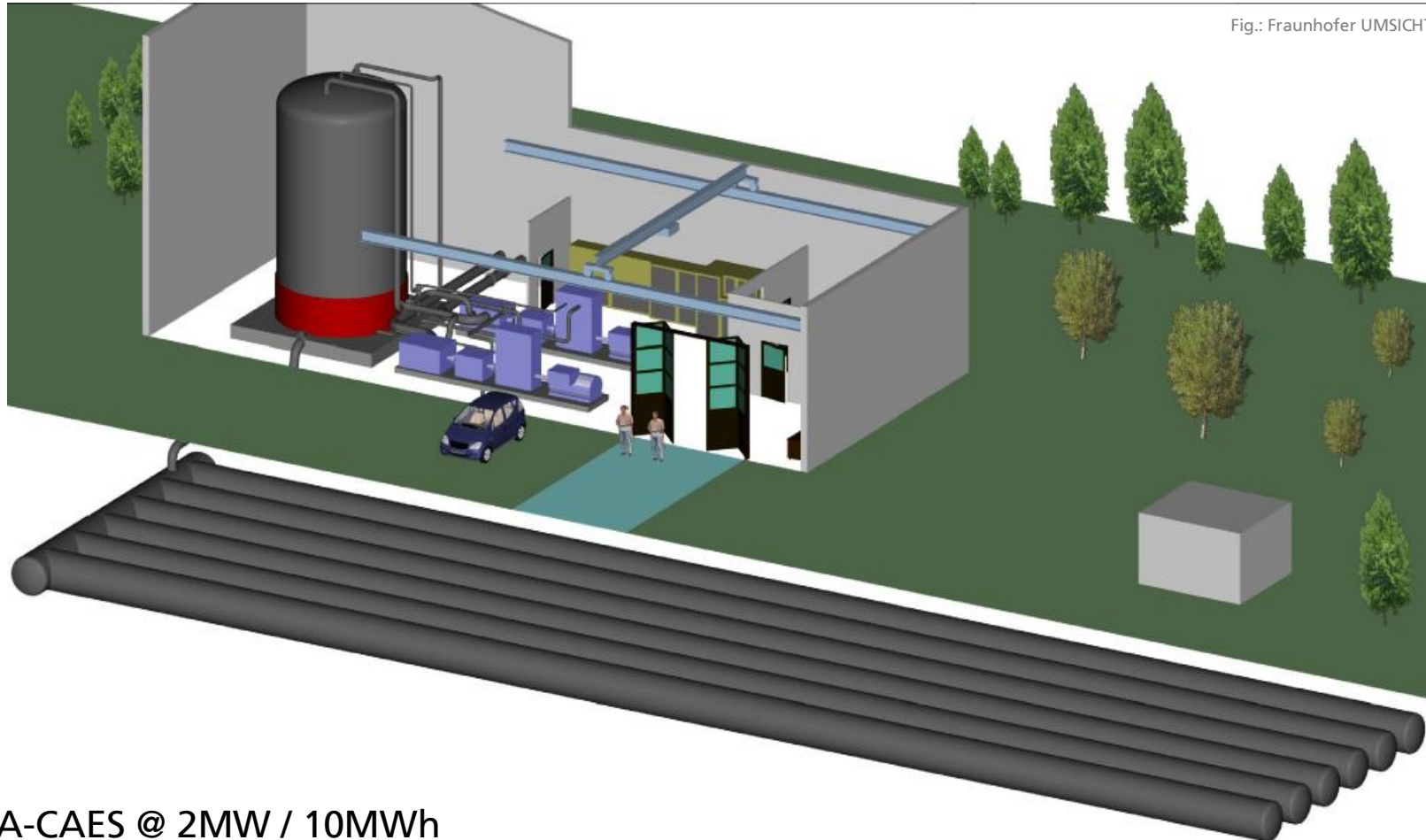

Fig.: Fraunhofer UMSICHT

A-CAES @ 2MW / 10MWh



**Excess heat in CAES systems**

# Excess heat in CAES systems

Excess heat - compression heat exceeds useable heat for expansion

à Excess heat in A-CAES system could lead to a TES-overload.

## Consequences:

- Air cannot be cooled down enough in the TES
- Higher compressor stages suffer greater thermal stresses
- Storage temperature inside the compressed air storage reaches safety relevant values
- Overall efficiency of the system decreases

## Basic principles:

- Non-isentropic compression and expansion
- Condensation and separation of humidity of ambient air

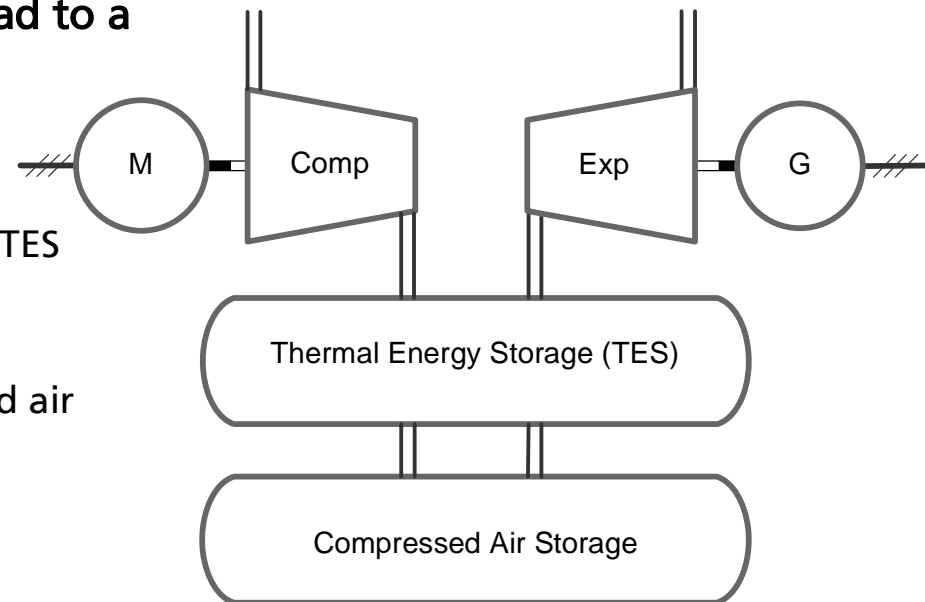
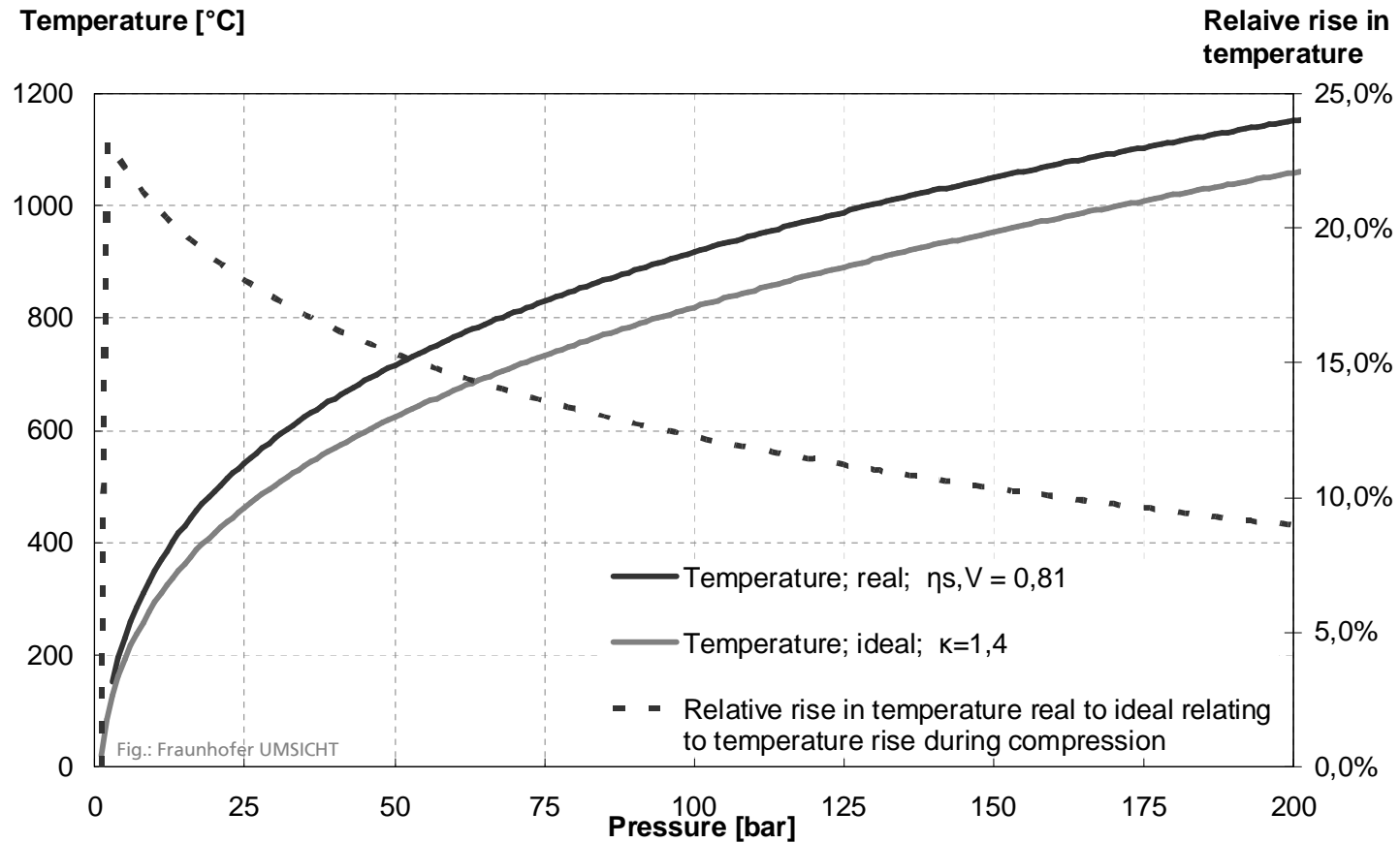

Fig.: Fraunhofer UMSICHT

# How hot compressed air can get!





# Non-isentropic compression and expansion

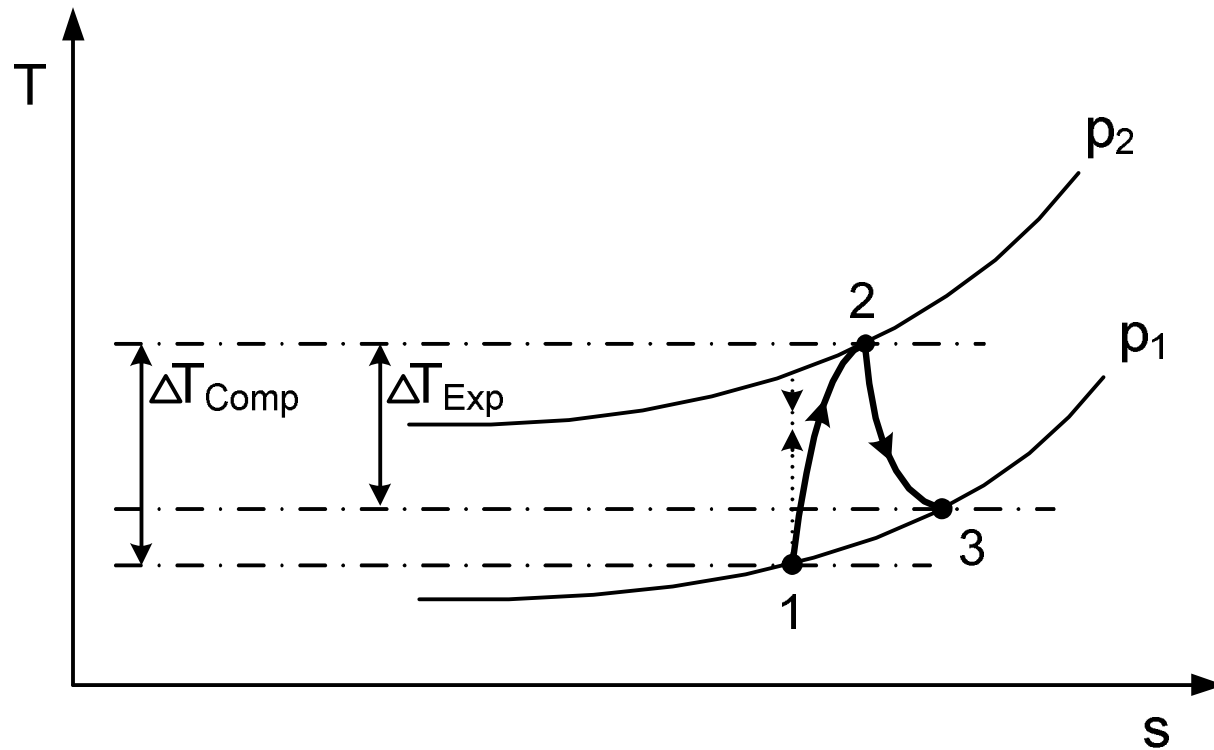

# Non-isentropic compression and expansion

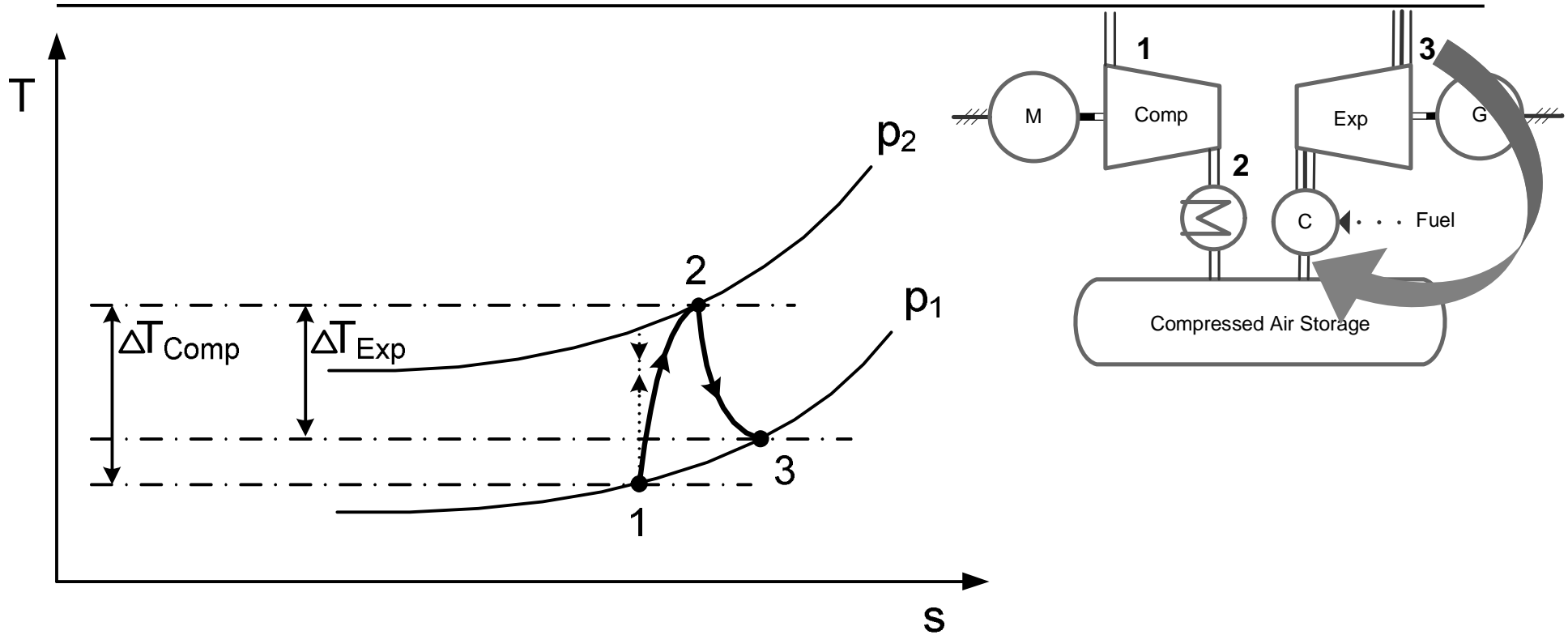

# Non-isentropic compression and expansion

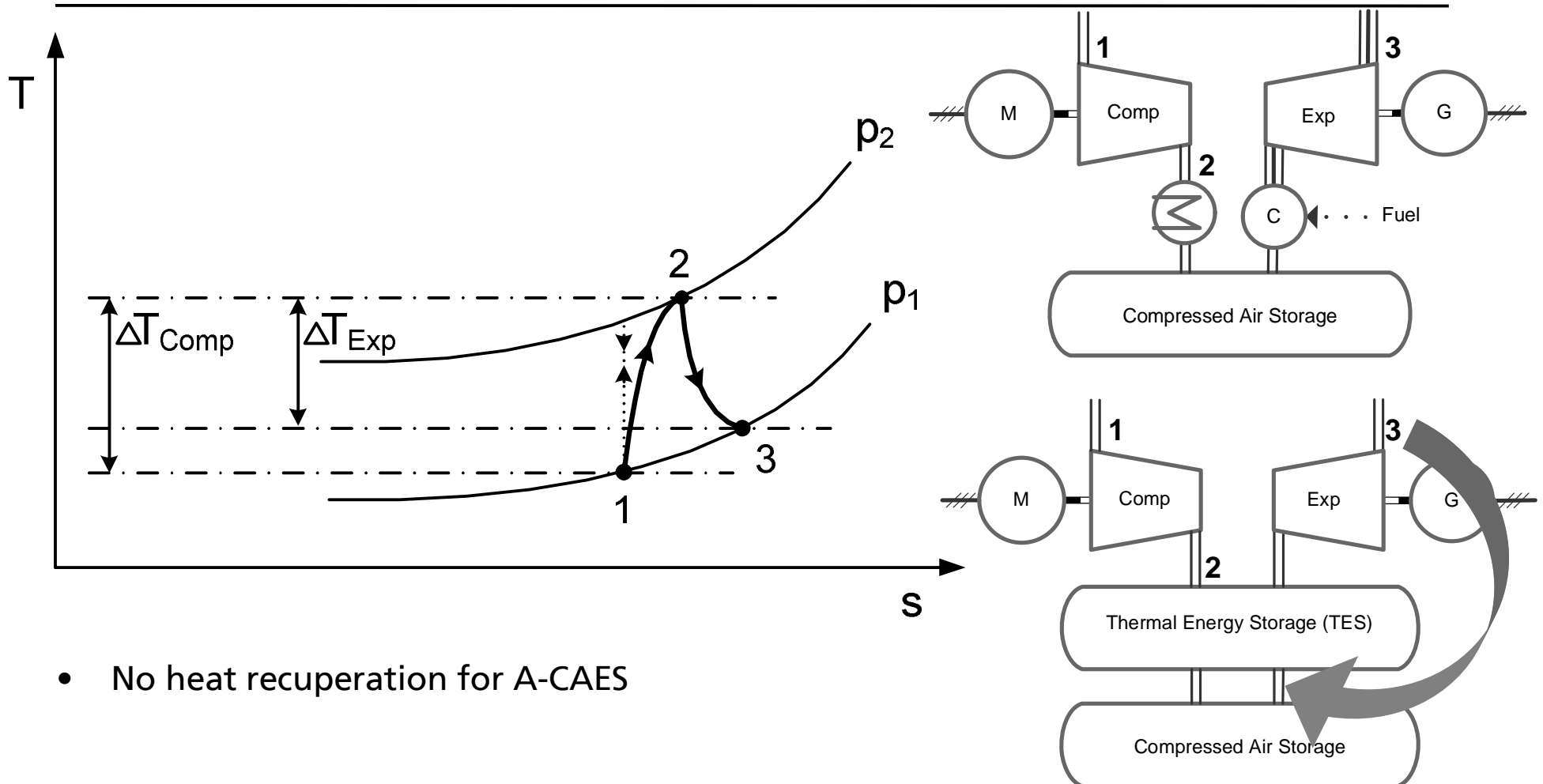

- No heat recuperation for A-CAES

# Non-isentropic compression and expansion

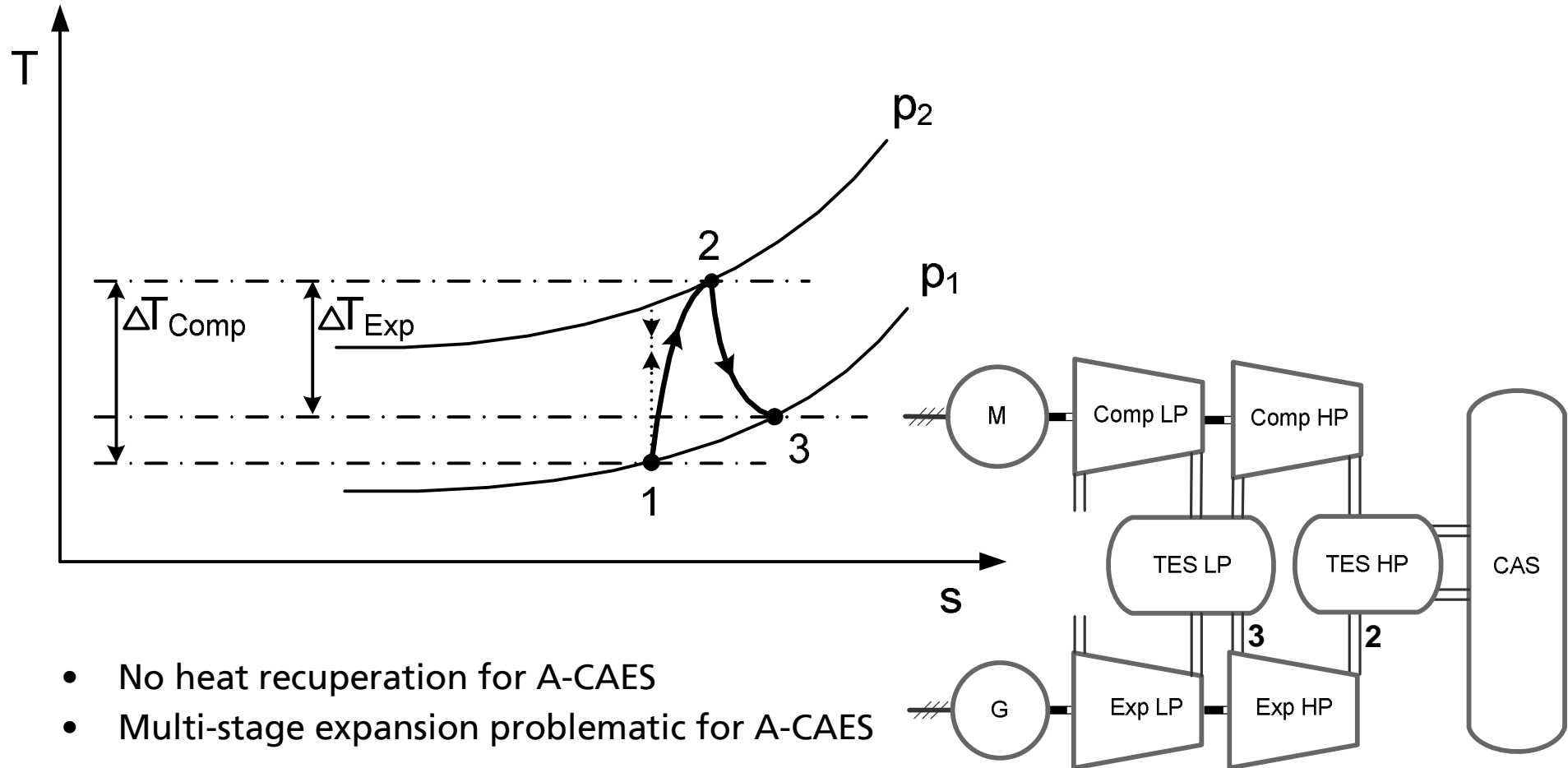

- No heat recuperation for A-CAES
- Multi-stage expansion problematic for A-CAES

# Influence of air humidity

---

- Ability of air to carry water increases with temperature and decreases with pressure
- Separated free water decreases the heat capacity flow of air during expansion

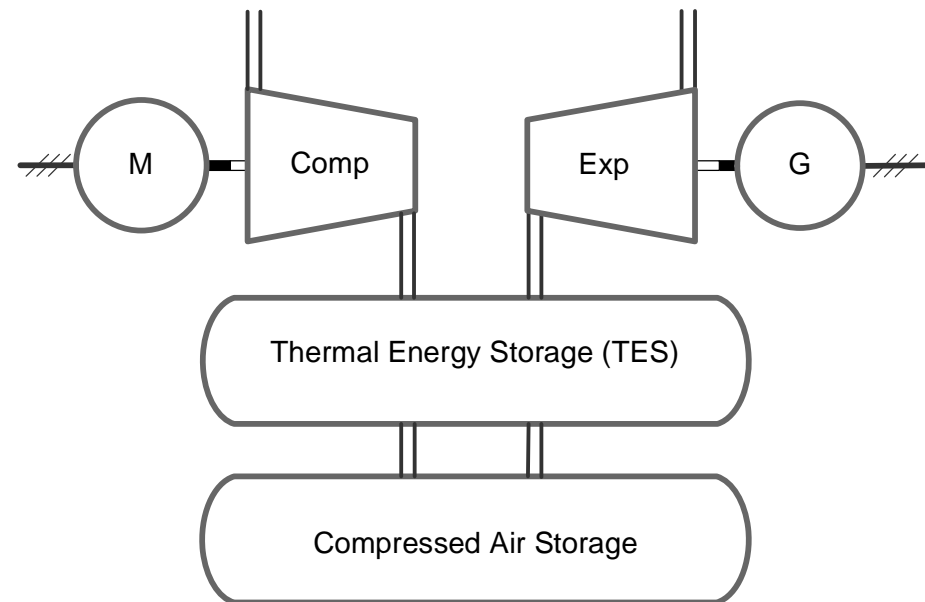

# Influence of air humidity

- Ability of air to carry water increases with temperature and decreases with pressure
- Separated free water decreases the heat capacity flow of air during expansion

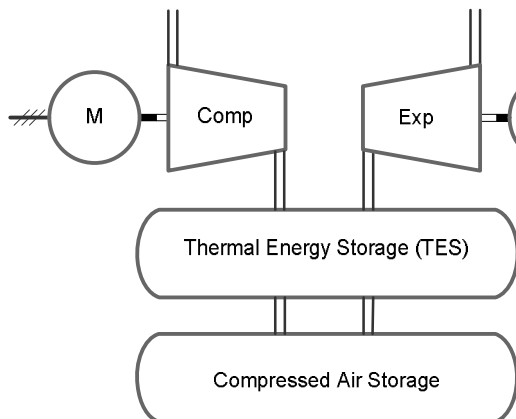

relative excess heat

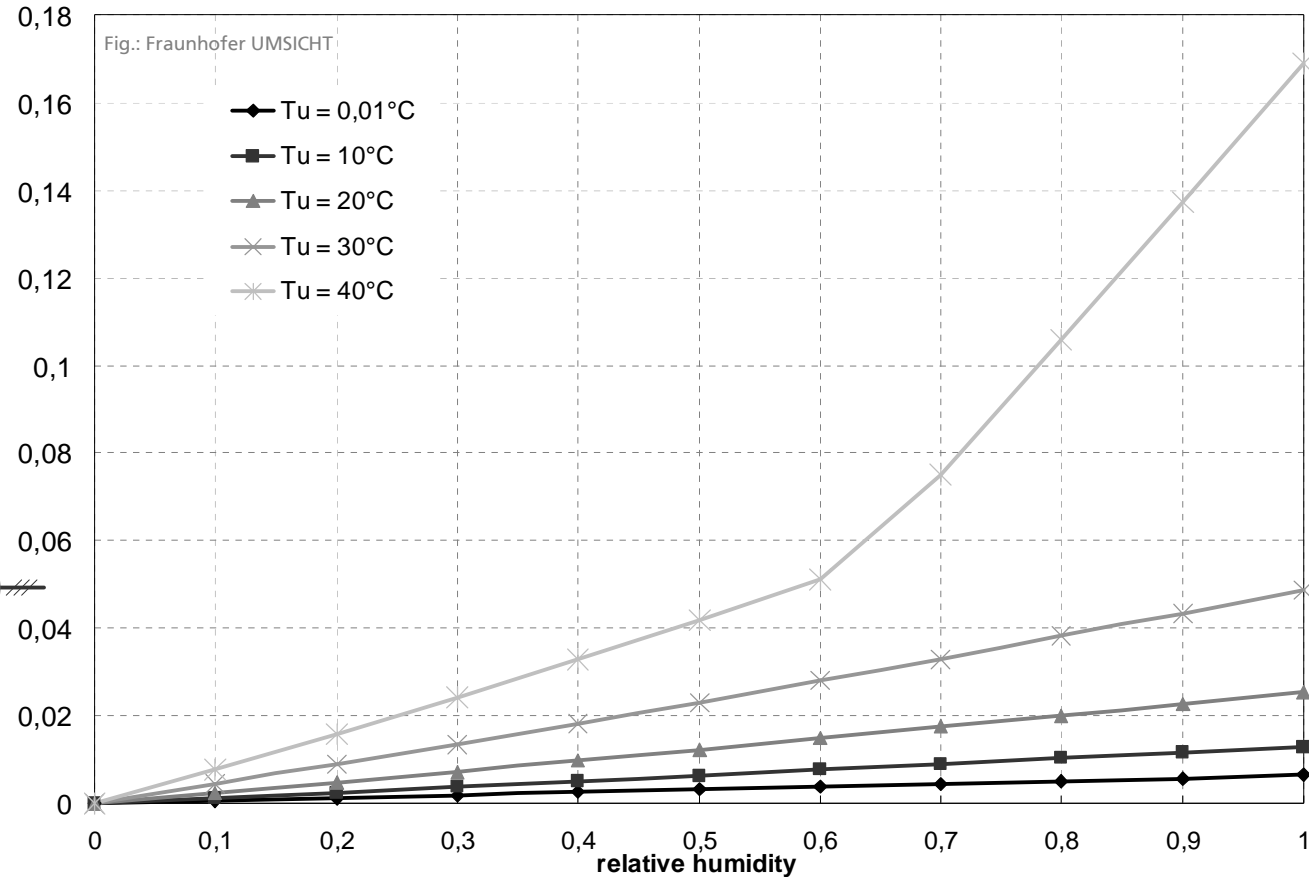

# Heat management solutions

# Heat management solutions for TES load balancing

---

## Basic intention of heat management:

à Enabling cyclic operation through an equilibrated TES load balance

## Possible solutions:

- Controlled re-cooling of the TES or air flow directly (1)
- Passive adaptation of thermal losses to excess heat (2)
- Injection of water to the airflow during reheating in the TES (3)
- Combined use of excess heat (4)  
(e.g. for an ORC-process, district heating)

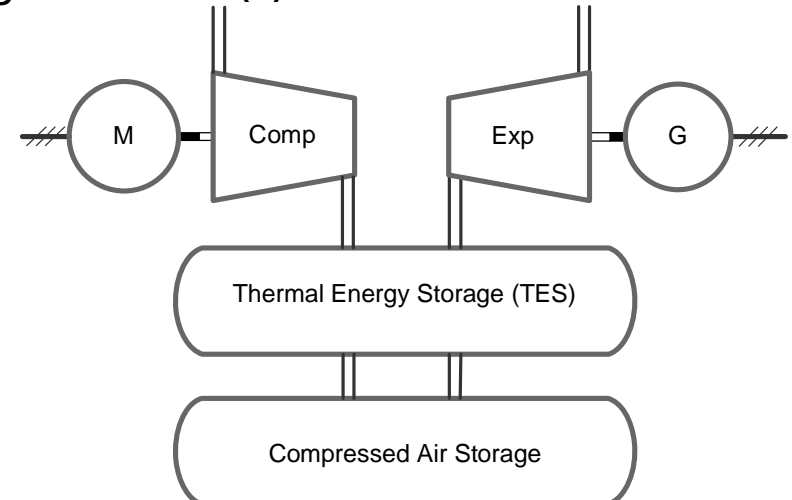



# Assessment of heat management solutions

	Financial effort	Technical effort	Operational Flexibility	Plant Efficiency
(1) Re-cooling	--	○	++	--
(2) Adaptation of thermal losses	++	++	-	--
(3) Water injection	-	--	+	++
(4) Combined use of excess heat	○	-	○	+

Table: Qualitative Assessment of possible heat management solutions for adiabatic compressed air storage plants ranging from highly favourable (++) to highly unfavourable (--)

- No single solution satisfies all needs!
- Since excess heat could be harvested on a relatively high temperature level the deployment of solution 3 or 4 should be investigated in detail
- à Demand for quantitative analysis of possible plant layouts

# Challenges for quantitative evaluation of heat management solutions

---

- Time dependant storage losses
- Decreasing isentropic efficiencies in part load operation
- Varying ambient conditions (temperature, humidity)



# Challenges for quantitative evaluation of heat management solutions

---

- Time dependant storage losses
- Decreasing isentropic efficiencies in part load operation
- Varying ambient conditions (temperature, humidity)

à Stationary calculations at design point are not sufficient for a proper plant design

**Solution:** Dynamic TES Model for the design of adiabatic CAES systems

# Dynamic Model of a stratified TES



Fig.: Ruhr-University Bochum

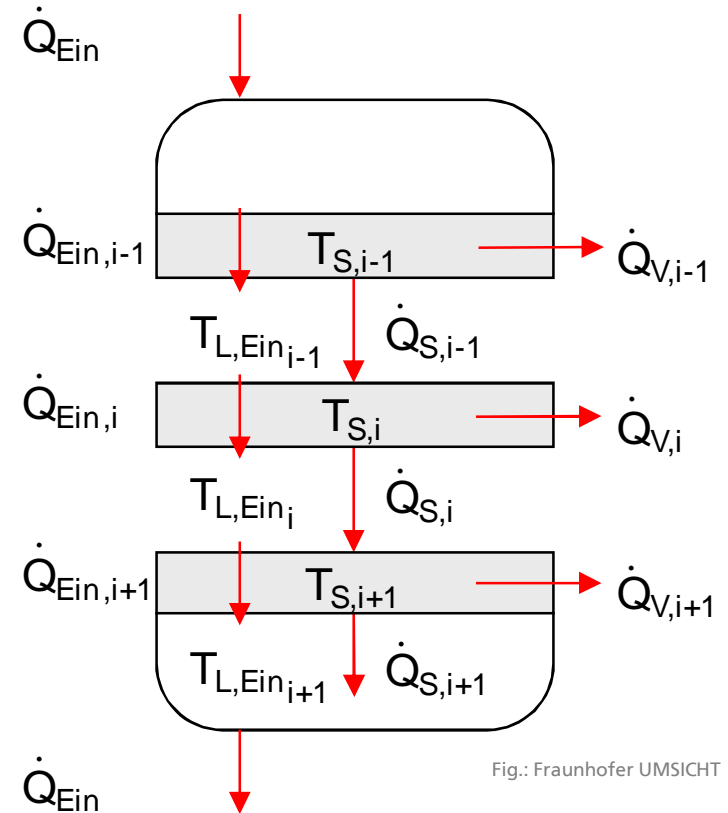

Fig.: Fraunhofer UMSICHT

- High temperature CAES-TES
- Molten salt at  $T_{\max} = 500^{\circ}\text{C}$

- One dimensional finite element approach
- Underlying real gas property models

# Dynamic Model of a stratified TES

Loading of TES:

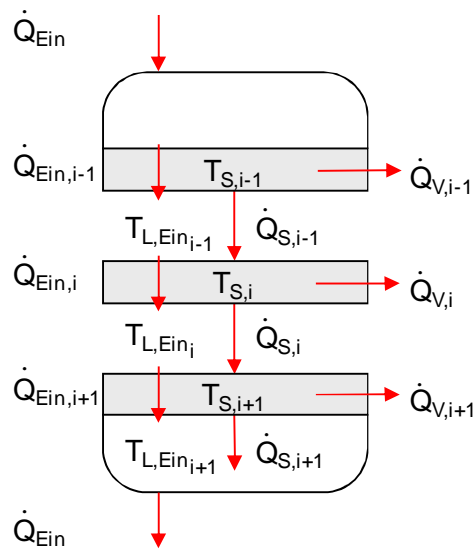

Temperature [°C]

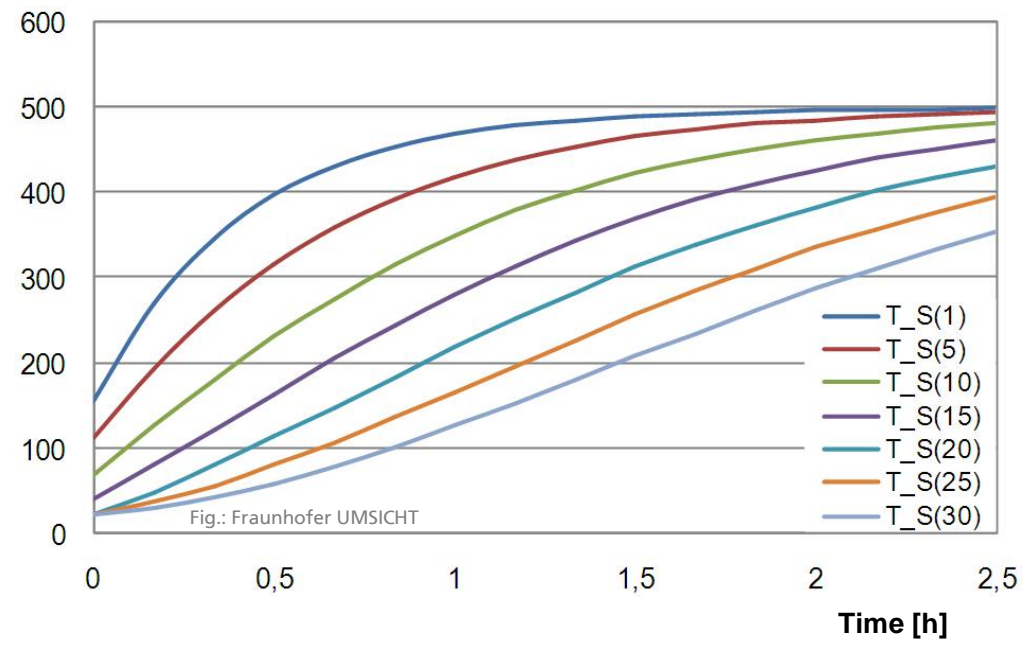

**Conclusion**

# Conclusion

---

- There is excess heat in the TES of an adiabatic CAES plant
  - § Excess heat due to non-isentropic compression and expansion could be avoided by omitting heat recuperation and multi stage TES
  - § Condensation of the air humidity as a second reason for excess heat in the TES cannot be avoided that easily
- à Necessity for TES heat management for safe and efficient operation of the A-CAES plant
- Four promising TES balancing solutions are proposed and evaluated qualitatively
- For a quantitative evaluation a dynamic computer model is proposed and currently under development