

---

# PORTABLE 100 W POWER GENERATOR BASED ON EFFICIENT PLANAR SOFC TECHNOLOGY

A. Pönicke, S. Reuber, C. Dosch, S. Megel, M. Kusnezoff, C. Wunderlich,  
A. Michaelis

---



ICACC'12 – 9<sup>th</sup> International Symposium on Solid Oxide Fuel Cells (SOFC):  
Materials, Science and Technology – Jan. 27, 2012, Daytona Beach, FL

---

# Fuel Cells at Fraunhofer IKTS

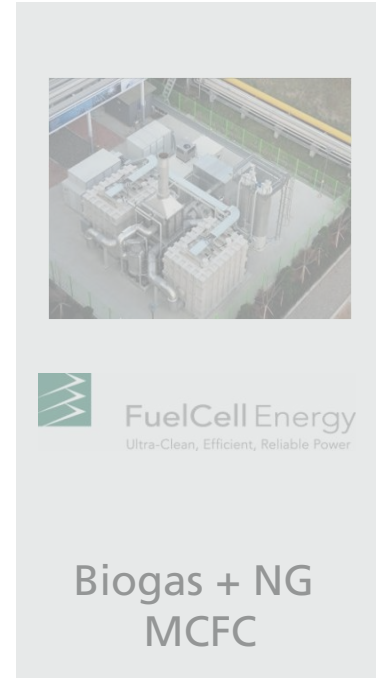
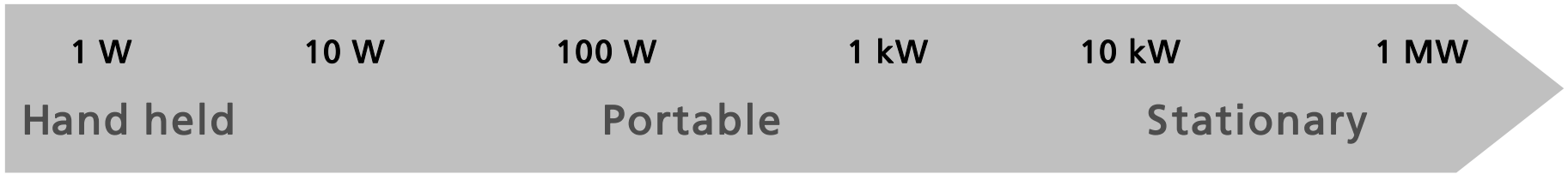

**eelleron**  
Power to go

**eneramic**  
by Fraunhofer

**Vaillant**

**FuelCell Energy**  
Ultra-Clean, Efficient, Reliable Power

Hydrogen  
PEMFC

Butane  
Tubular SOFC

LPG  
SOFC

Natural gas  
SOFC

Biogas  
SOFC

Biogas + NG  
MCFC

---

# PORTABLE 100 W POWER GENERATOR BASED ON EFFICIENT PLANAR SOFC TECHNOLOGY

---

- eneramic<sup>®</sup> system concept
- Stack testing
  - Performance
  - Long-term stability
  - Thermal cycling
  - Performance in system environment
- Summary



# Objectives

Infrastructure fuel  
Water free operation  
Lightweight and simple

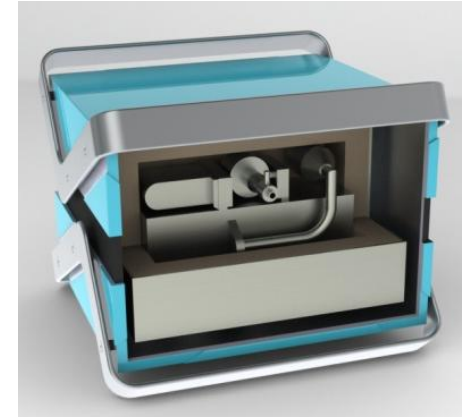

## IKTS planar SOFC technology

- Portable LPG system
- 100 W<sub>DC</sub> electric power @ 12 V
- Fully grid independent operation



## Target applications

- Caravan integration
- Outdoor applications
- Security / traffic / environmental monitoring
- Remote power supply

# Objectives

Infrastructure fuel  
Water free operation  
Lightweight and simple



## Life time targets

- > 3,000 h long-term stability
- 300 thermal cycles

## IKTS planar SOFC technology

- Portable LPG system
- 100 W<sub>DC</sub> electric power @ 12 V
- Fully grid independent operation

## Target applications

- Caravan integration
- Outdoor applications
- Security / traffic / environmental monitoring
- Remote power supply



# eneramic<sup>®</sup> System Concept

## System Core

- Compact system design
- High thermal integration for maximum efficiency
- Robust system configuration
- Multilayer technology based design
- Integrated manifolds
- Reduction of piping and pressure losses
- Ease of fabrication

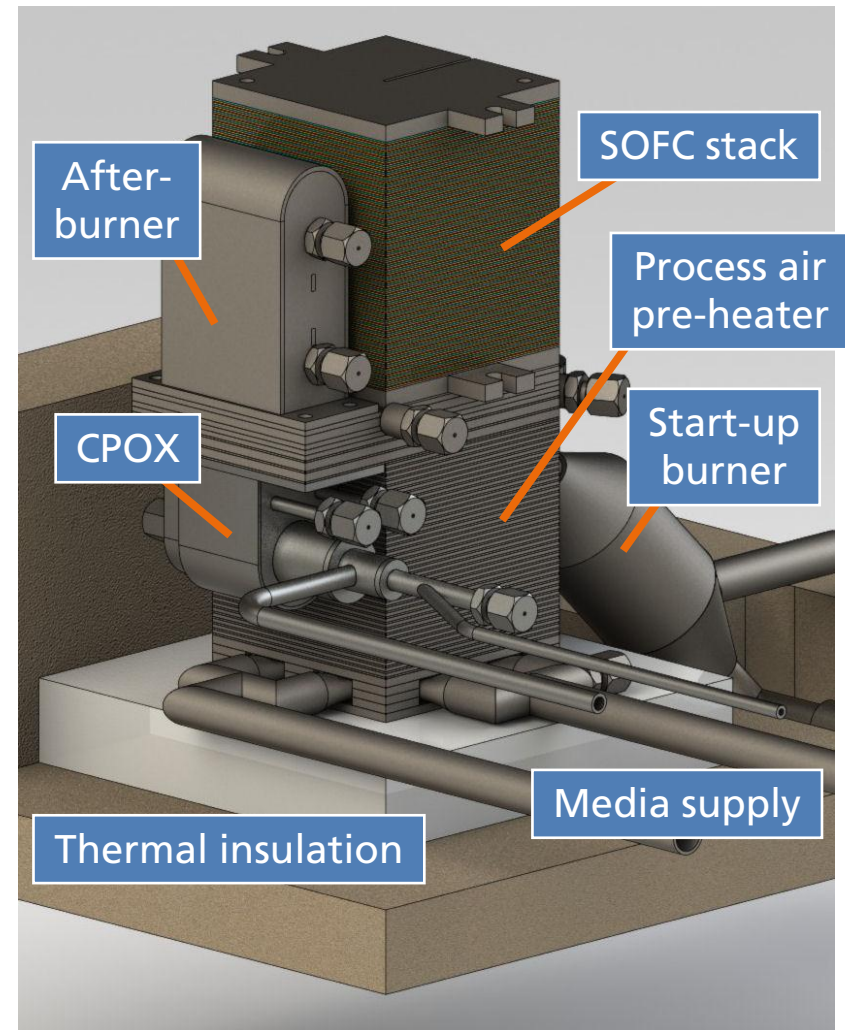

# eneramic<sup>®</sup> System Concept

## System Core

- Compact system design
- High thermal integration for maximum efficiency
- Robust system configuration
- Multilayer technology based design
- Integrated manifolds
- Reduction of piping and pressure losses
- Ease of fabrication

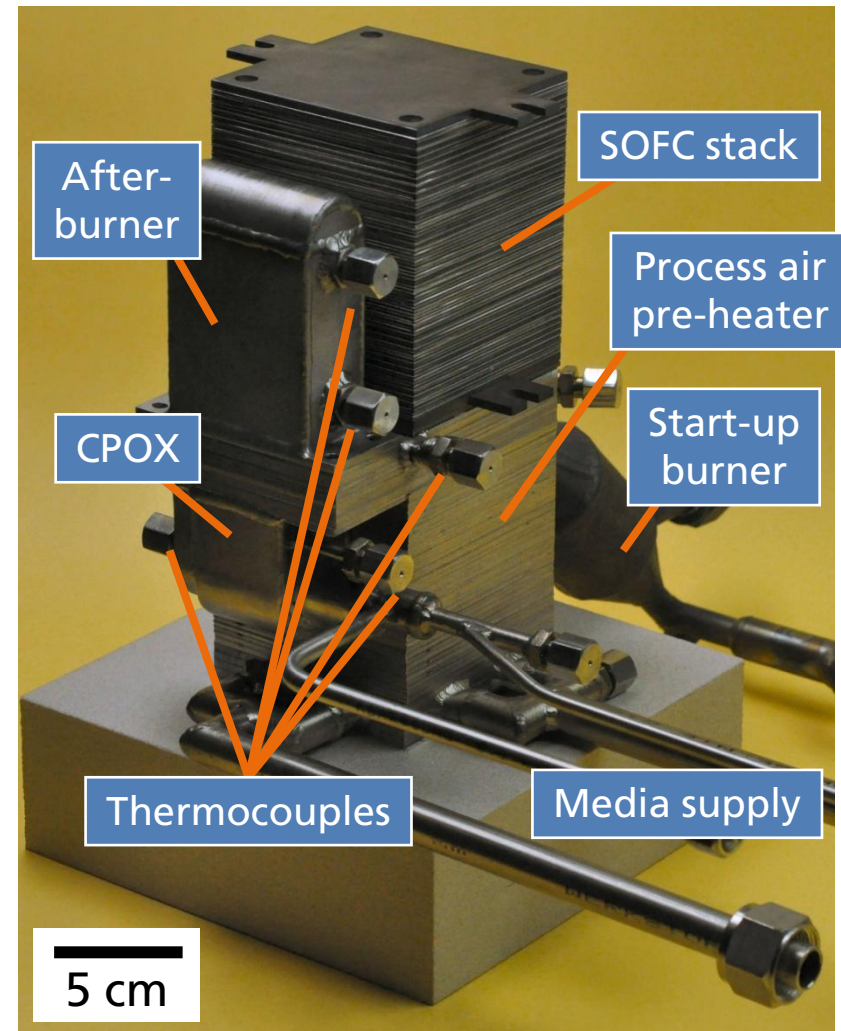

# eneramic® System Concept

## Stack Design

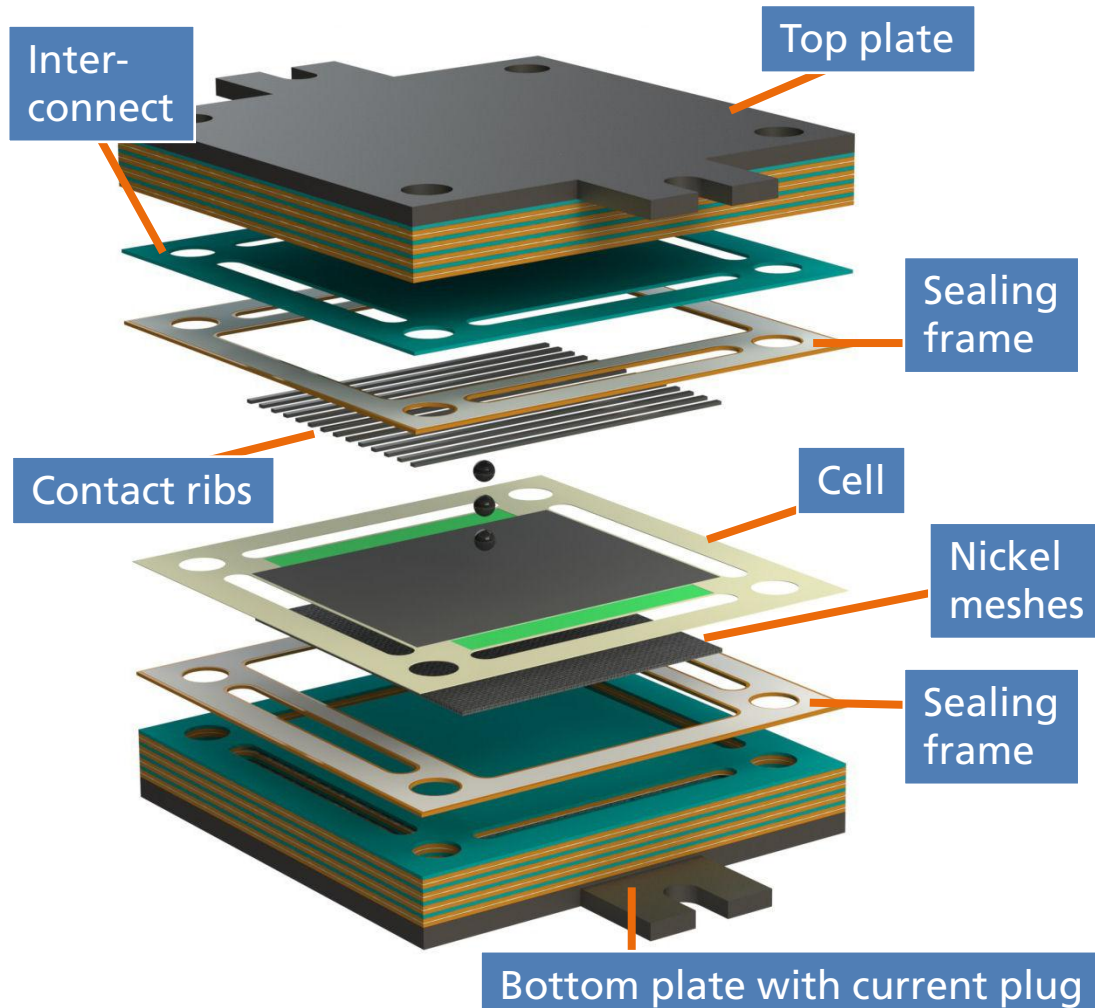

- Planar stack technology featuring
  - Crofer22APU interconnect
  - 3YSZ based electrolyte supported cell
  - $\text{SiO}_2\text{-Al}_2\text{O}_3\text{-BaO}$  sealing glass
- Stack design with focus on fabrication
  - Laser cutting
  - Screen printing
  - Dispensing

# Stack Testing Experimental Setup

## Furnace testing

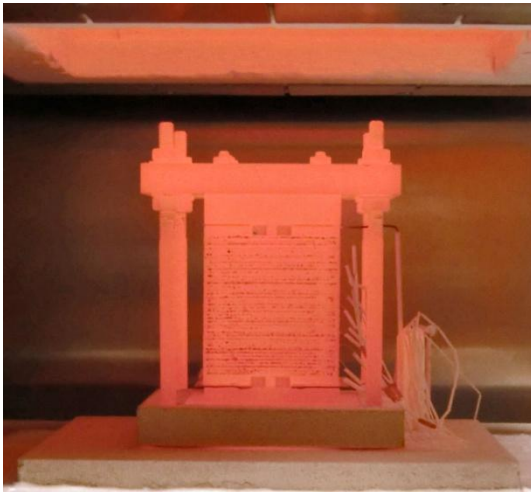

- Gas supply:  $H_2$ ,  $N_2$ ,  $H_2O$ ,  $CO$ ,  $CO_2$ ,  $CH_4$
- Cycling + long-term testing
- Impedance spectroscopy

## Hotbox testing



- Gas supply:  $H_2$ ,  $N_2$ ,  $H_2O$
- Pre-heated gases
- Long-term testing

## Prototype system

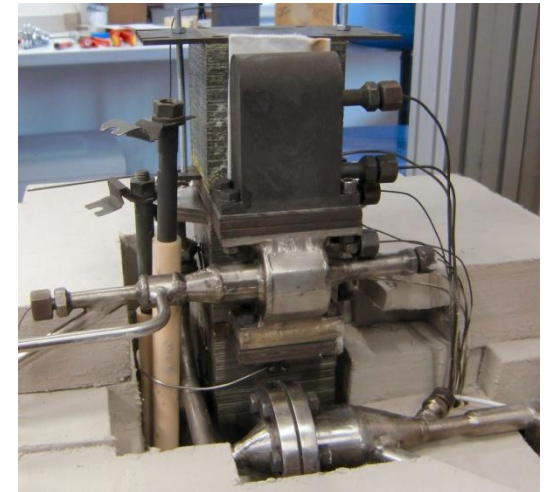

- Fuel supply: propane, butane, LPG
- System operation with CPOx reformer

# Stack Performance

## Current-voltage Characteristics

40-cell stack with Ni/GDC anode

Simulated reformat,  $H_2/N_2/H_2O = 48/48/4$ ,  $V_{gas} = 280$  sl/h

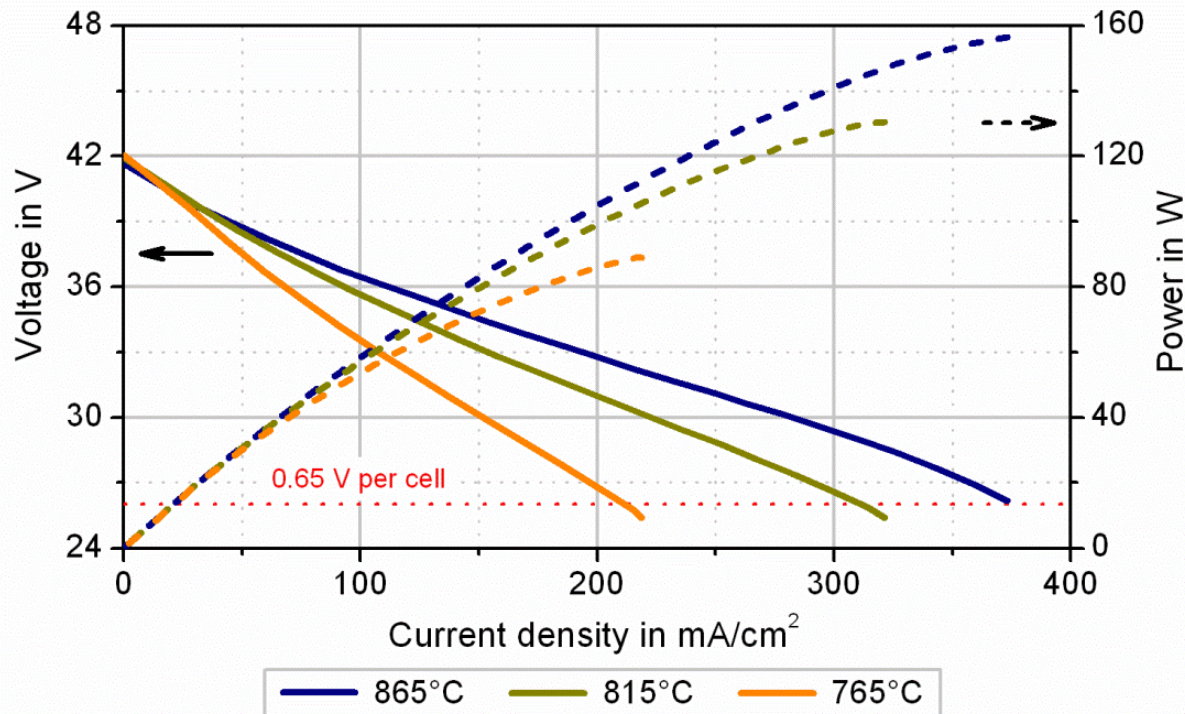

- Current densities at:
  - 865°C, nominal stack operating temperature = 375 mA/cm<sup>2</sup>
  - 765°C, start-up temperature = 210 mA/cm<sup>2</sup>
- Stack operation at lower temperatures accelerates system start-up

# Stack Performance

## ASR Measurement

- Cell with Ni/8YSZ anode
  - ASR = 0.65-0.75  $\Omega \cdot \text{cm}^2$

- Optimization through further development at cell & stack level

- Cell with Ni/GDC anode
  - ASR = 0.55-0.61  $\Omega \cdot \text{cm}^2$

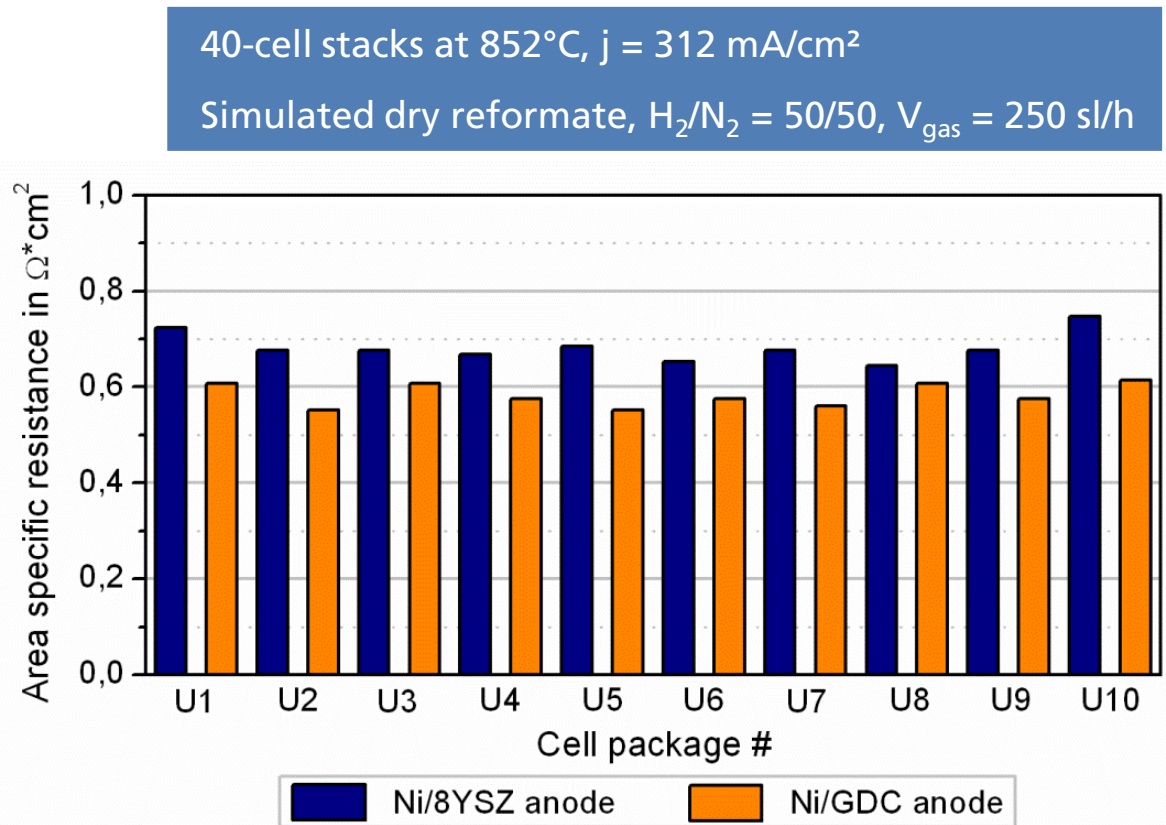

# Long-term Stability

## 5-cell Stack in Furnace

5-cell stack with Ni/8YSZ anode

Simulated reformat,  $H_2/N_2/H_2O = 48/48/4$

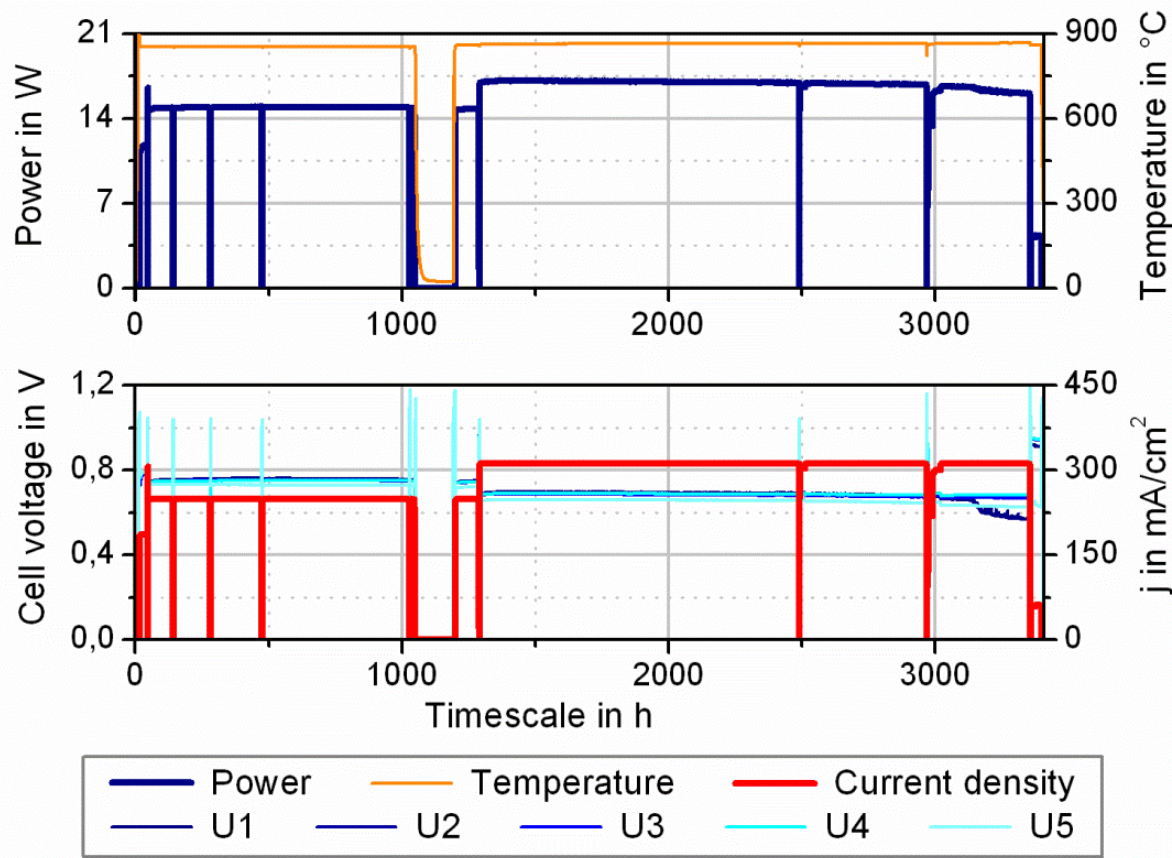

- Stack @ 855 °C
- $j = 250 \text{ mA/cm}^2$   
and  $= 312 \text{ mA/cm}^2$
- Stack activation during first 260 hours:  
 $P_{\max} = 14.9 \text{ W}$
- Power degradation  $< 1 \text{ \%}/1,000 \text{ h}$
- Emergency stop after 3,000 h caused rapid voltage drop

# Long-term Stability

## 5-cell Stack in Furnace

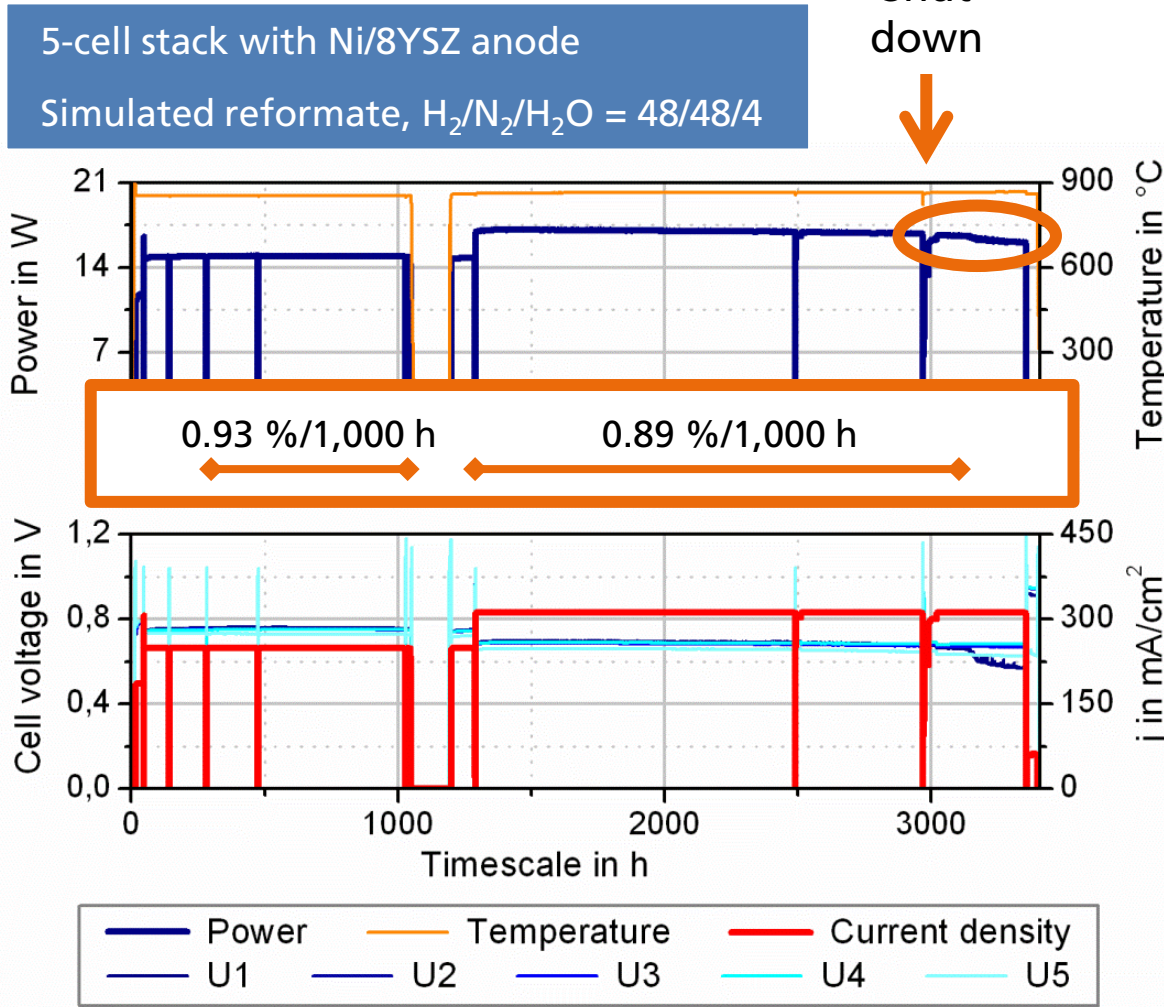

- Stack @ 855 °C
- $j = 250 \text{ mA/cm}^2$   
and  $= 312 \text{ mA/cm}^2$
- Stack activation during first 260 hours:  
 $P_{\max} = 14.9 \text{ W}$
- Power degradation < 1 %/1,000 h
- Emergency stop after 3,000 h caused rapid voltage drop

# Long-term Stability

## Impedance Spectroscopy of 5-cell Stack

- Impedance spectra were taken
  - At initial state (24 h)
  - During long-term operation
- Reduction of anode resistance during stack operation → further activation
- Increase of ohmic resistance after 3,000 hours → post-test analysis

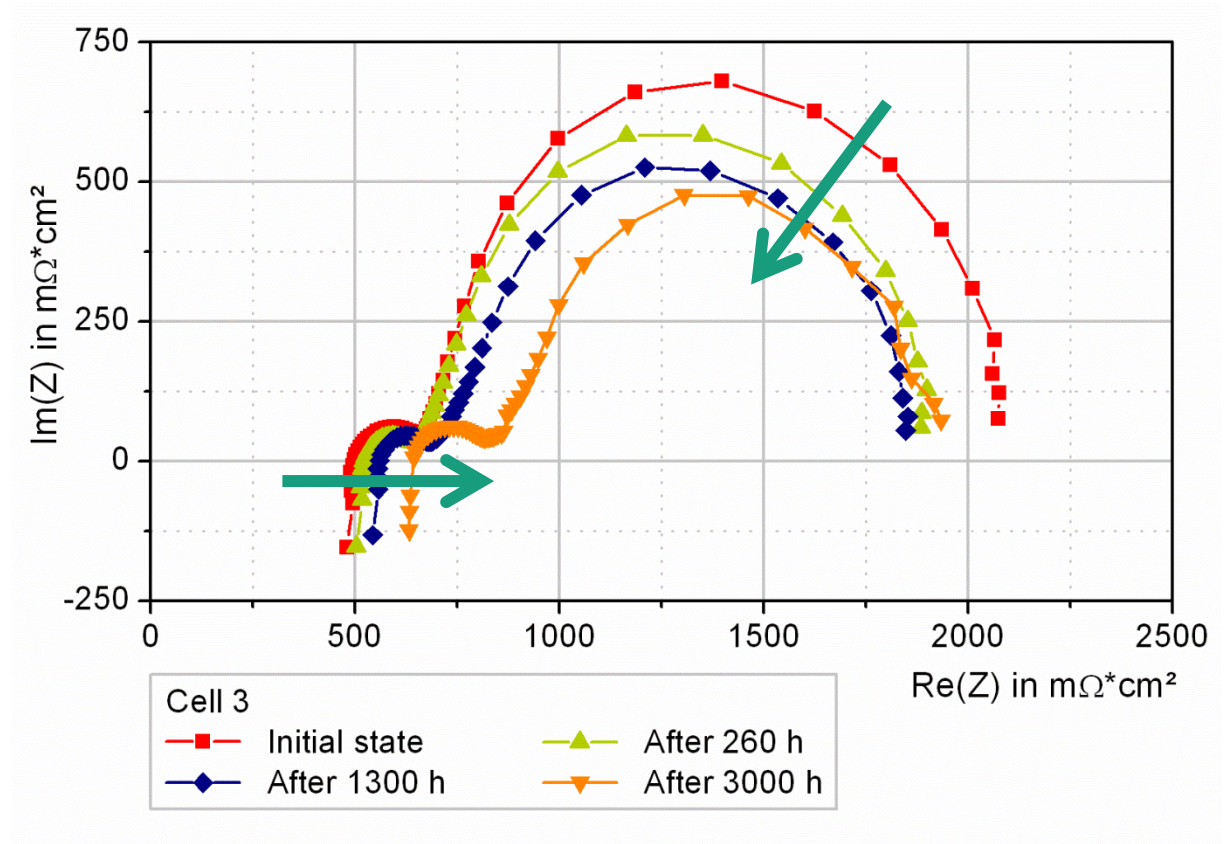

# Long-term Stability

## Post-test Analysis of 5-cell Stack

- Increase of ohmic resistance due to oxide formation at cathode side  
→ Thickness increased to 10-18  $\mu\text{m}$
- Emergency stop caused spelling of cathode contact ribs of cell 1 and 5  
→ Rapid degradation of cell voltages

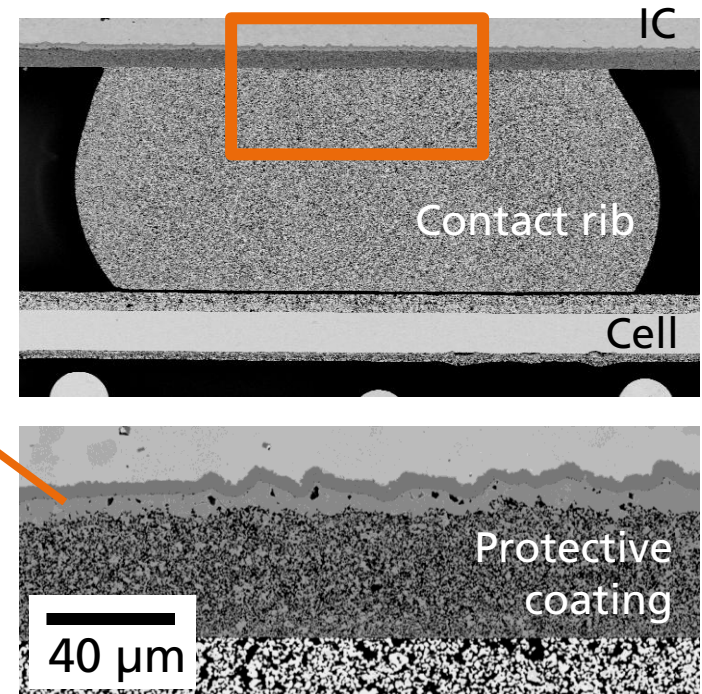

Cross cut through embedded stack after 3,300 hours

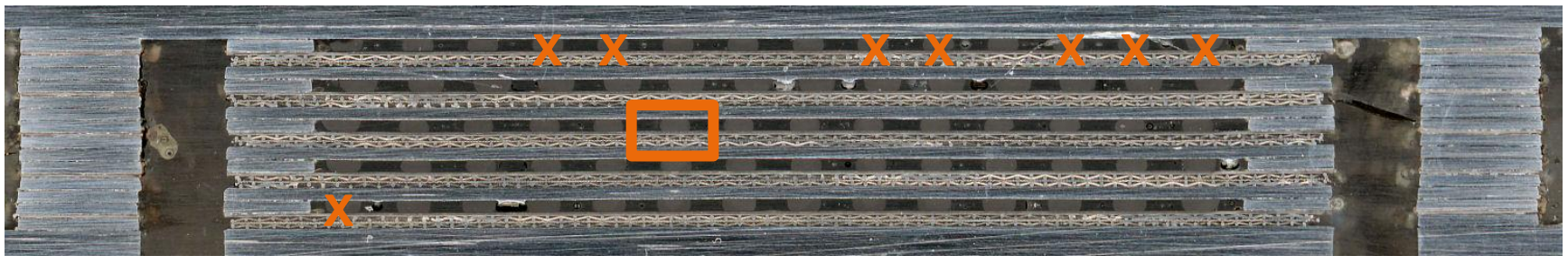

# Long-term Stability

## 40-cell Stack in Hotbox

40-cell stack with Ni/8YSZ anode

Simulated reformat,  $H_2/N_2/H_2O = 48/48/4$ ,  $FU = 69\%$

- Stack @ 859 °C
- $j = 312 \text{ mA/cm}^2$
- $P_{\text{max}} = 140.2 \text{ W}$
- After 2,200 hours and 4 cycles:  
 $P_{\text{end}} = 133.8 \text{ W}$
- Rapid degradation of 1<sup>st</sup> cell package
- Calculated overall power degradation  
→ 2.1 %/1,000 h

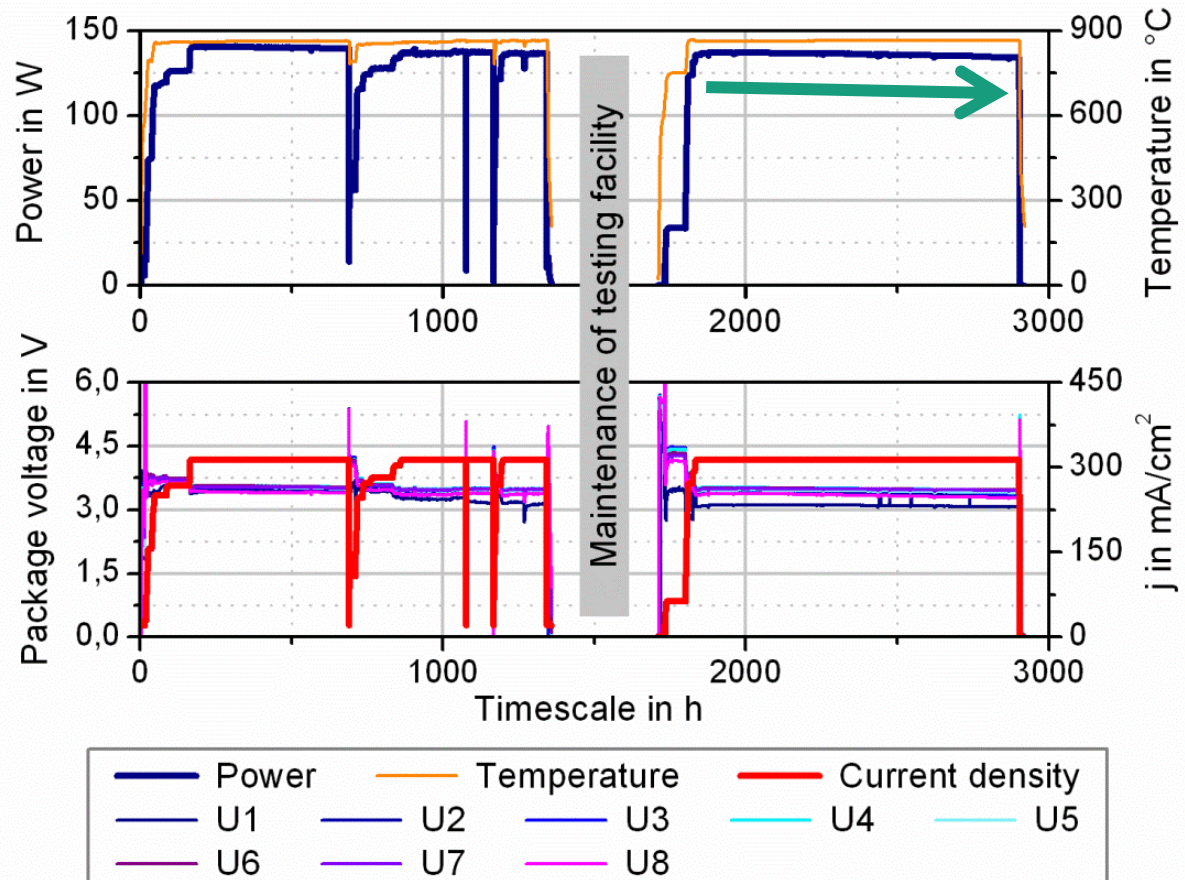

# Long-term Stability

## 40-cell Stack in Hotbox

40-cell stack with Ni/8YSZ anode

Simulated reformat,  $H_2/N_2/H_2O = 48/48/4$ ,  $FU = 69\%$

- Stack @ 859 °C
- $j = 312 \text{ mA/cm}^2$
- $P_{\text{max}} = 140.2 \text{ W}$
- After 2,200 hours and 4 cycles:  
 $P_{\text{end}} = 133.8 \text{ W}$
- Rapid degradation of 1<sup>st</sup> cell package
- Calculated overall power degradation  
→ 2.1 %/1,000 h

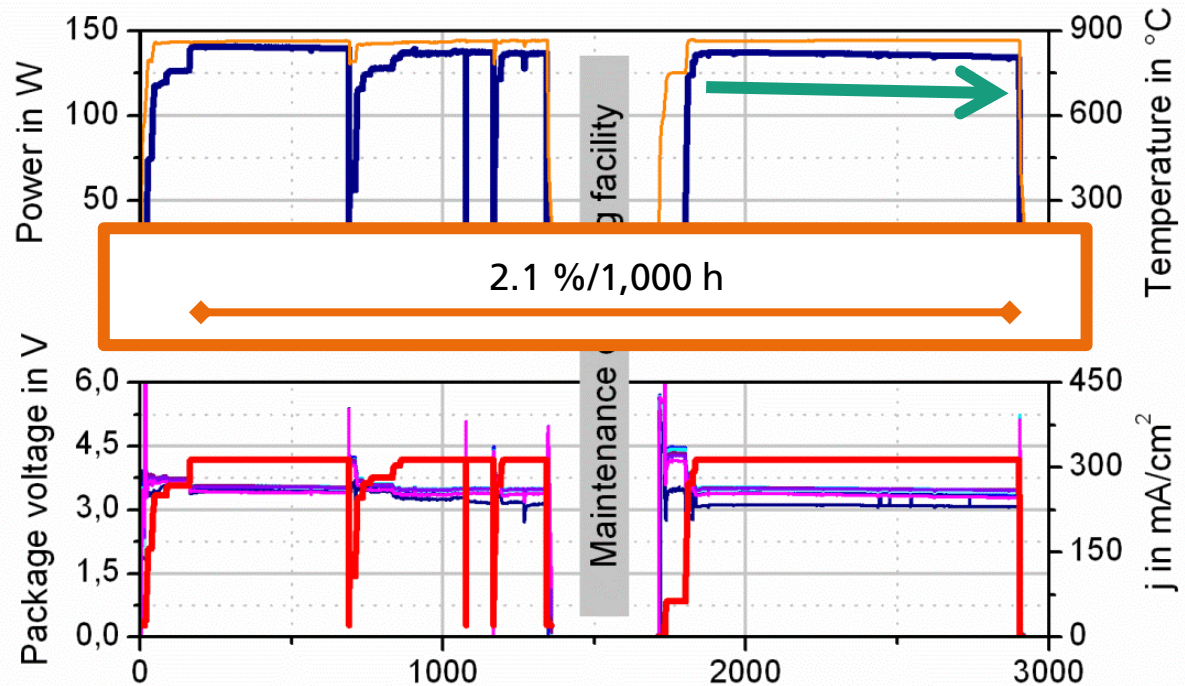

Power output  $> 130 \text{ W}_{\text{DC}}$  is still enough for the user and the parasitic BoP components of the eneramic<sup>®</sup> system!

# Thermal Cycling

## 5-cell Stack in Furnace

5-cell SOFC stack with Ni/8YSZ anode  
Simulated reformat,  $H_2/N_2/H_2O = 48/48/4$

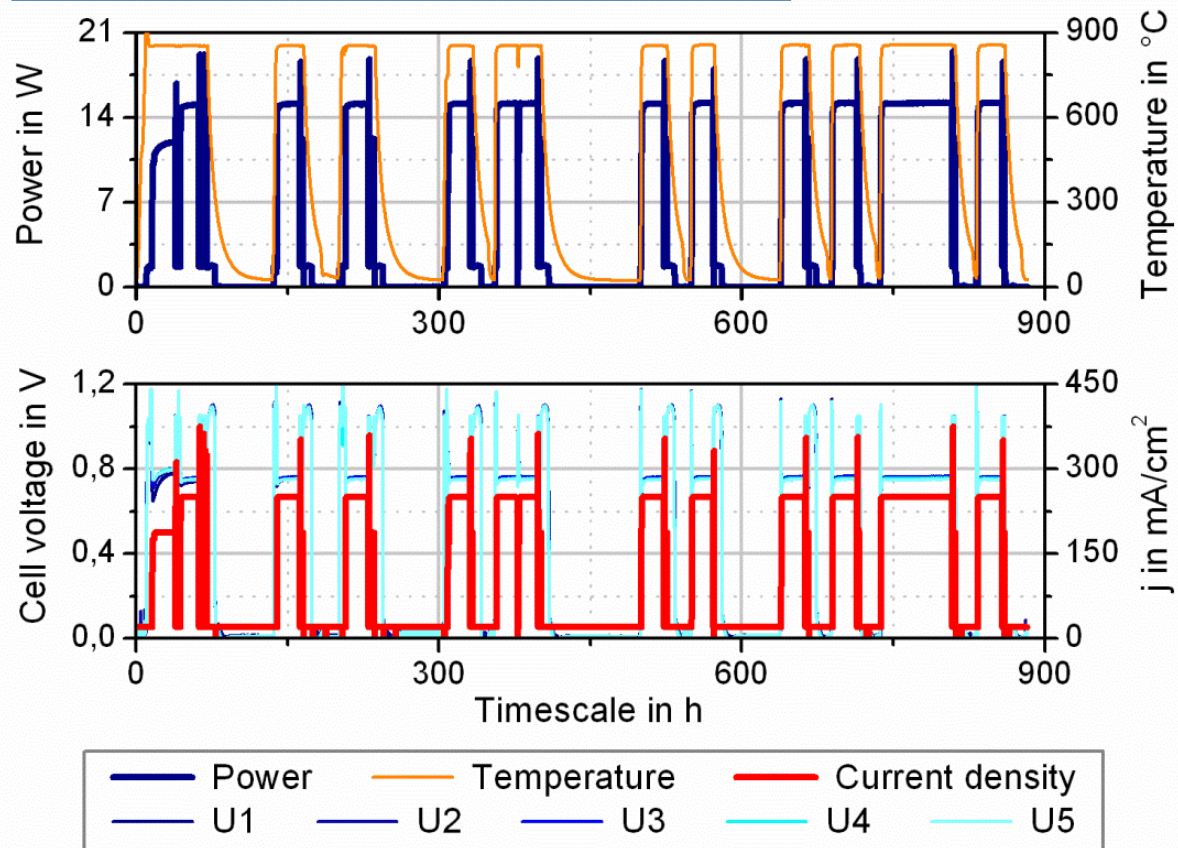

- 5 K/min heating rate
- 11 cycles
- Always after 20 h
- Cell voltage distribution 0.75-0.76 V
- Initial state after cycling
- Decreased cell voltages
- Re-activation due to reversible contact losses at the anode

# Performance in System Environment

## 40-cell Stack in Prototype System

- Stack @ 859 °C
- $j = 288 \text{ mA/cm}^2$
- $P_{\text{max}} = 133.9 \text{ W}$
  
- After 200 hours:  
 $P_{\text{end}} = 131.9 \text{ W}$
- Overall power degradation  
→ 4.1 %/1,000 h
- Observed voltage drops of upper cells
- $\Delta P/P_0$  for U1-U8  
→ 2.3 %/1,000 h

40-cell stack with Ni/GDC anode, CPOx reformat, FU = 71 %

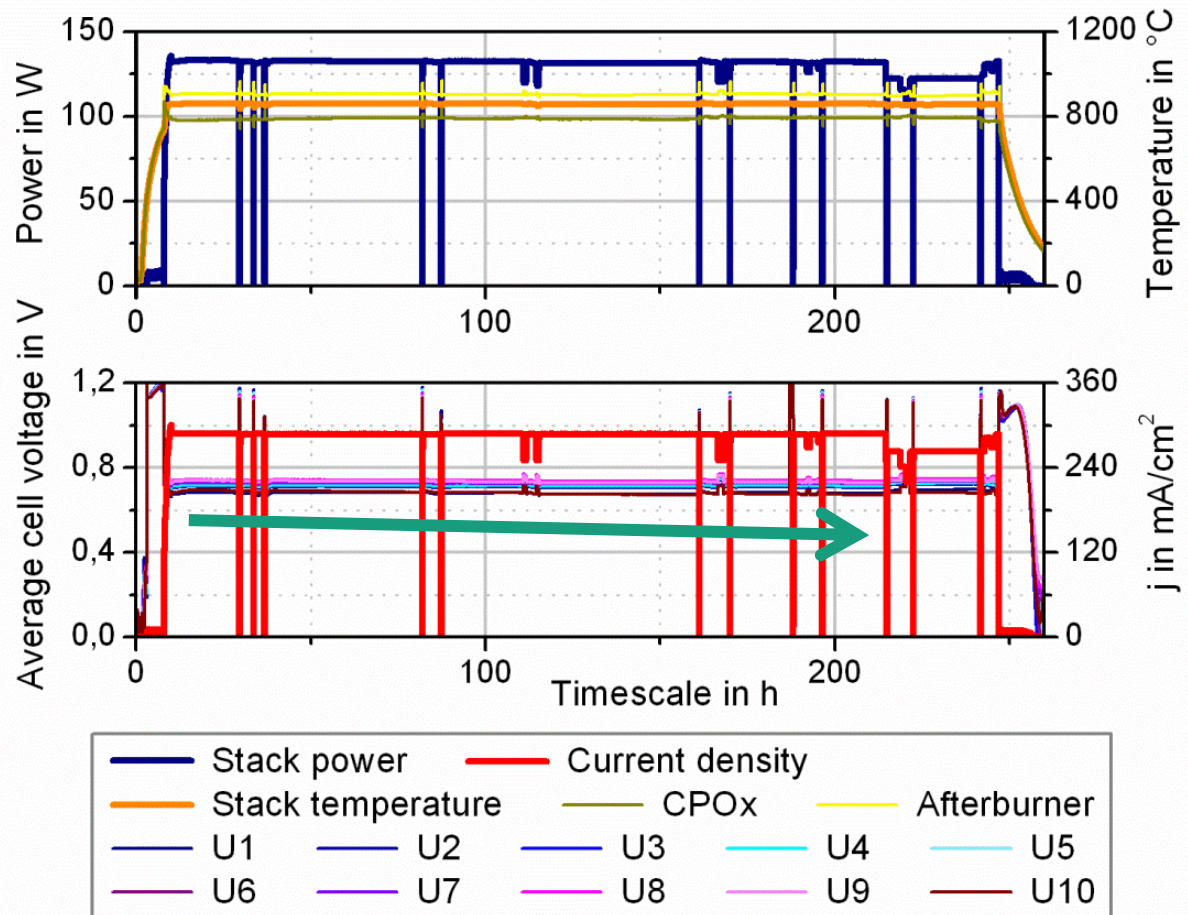

# Performance in System Environment

## 40-cell Stack in Prototype System

- Stack @ 859 °C
- $j = 288 \text{ mA/cm}^2$
- $P_{\text{max}} = 133.9 \text{ W}$
- After 200 hours:  
 $P_{\text{end}} = 131.9 \text{ W}$
- Overall power degradation  
→ 4.1 %/1,000 h
- Observed voltage drops of upper cells
- $\Delta P/P_0$  for U1-U8  
→ 2.3 %/1,000 h

40-cell stack with Ni/GDC anode, CPOx reformat, FU = 71 %

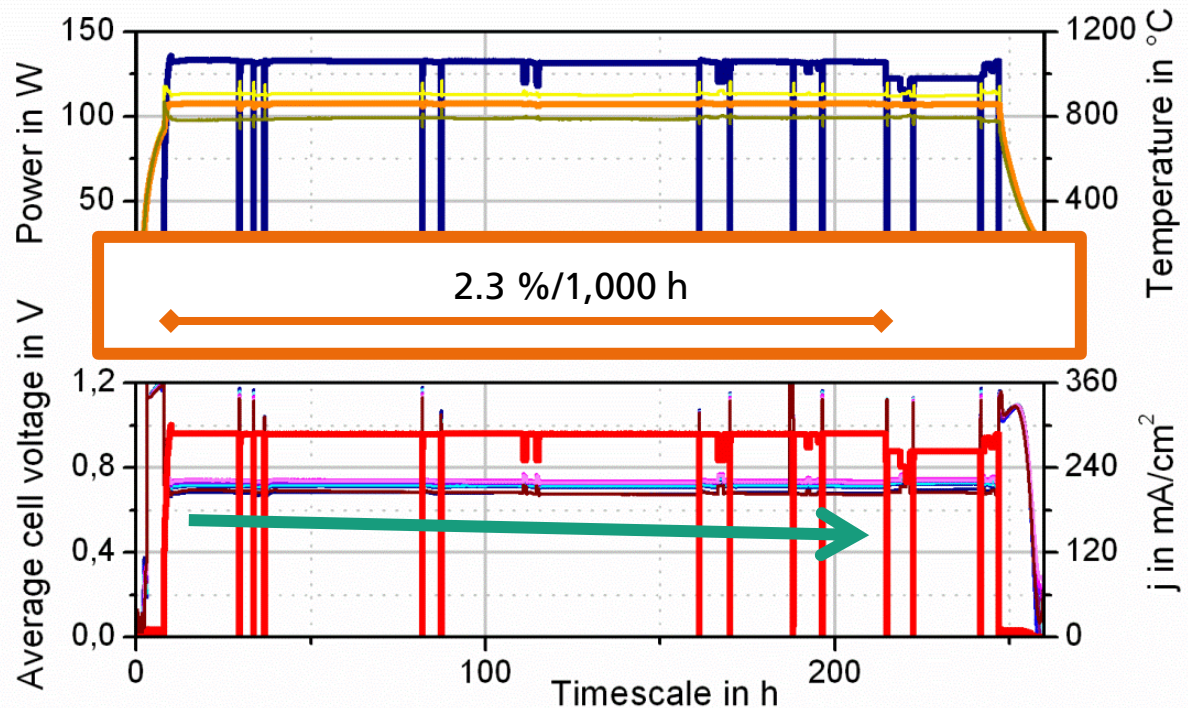

Insufficient compression of stack during system operation caused voltage drops of upper cells!

- Portable  $\mu$ -SOFC system based on ceramic components and multilayer technologies fueled with LPG
- Planar SOFC stack technology with Ni/8YSZ and Ni/GDC anode
  - 150 W power output of 40-cell stack
  - $\Delta P/P_0 < 1 \%$ /1,000 h @ long-term testing
  - $\Delta P/P_0 = 2.1 \%$ /1,000 h @ hotbox testing
  - $\Delta P/P_0 = 2.3 \%$ /1,000 h @ prototype system
- Next steps
  - Long-term testing of Ni/GDC anode
  - Real-life cycle testing with harsh gradients



# Thank you for your attention!

- The  **eneramic**<sup>®</sup> project team.  
by Fraunhofer
- Thanks for financial support of the *Fraunhofer Future Foundation*

## Contact

- **Andreas Pönicke**  
andreas.poenicke@ikts.fraunhofer.de
- **Dr. Christian Wunderlich**  
christian.wunderlich@ikts.fraunhofer.de

Stay tuned @ [www.eneramic.de](http://www.eneramic.de)



For the latest update on the eneramic® system join us at:

HANNOVER MESSE 2012  
April 23 – 27, Hall 27, B 66

H2FC-FAIR  
Tobias Renz FAIR

GRUPEXHIBIT  
HYDROGEN  
FUEL CELLS

HANNOVER MESSE 2012  
8 international Tradeshows

Hannover, 23 - 27 April 2012



10th CMCEE



International Symposium on  
Ceramic Materials and Components  
for Energy and Environmental Applications

May 20-23, 2012  
Dresden, Germany



Lucerne, Switzerland

# Project Approach of the Fraunhofer Future Foundation

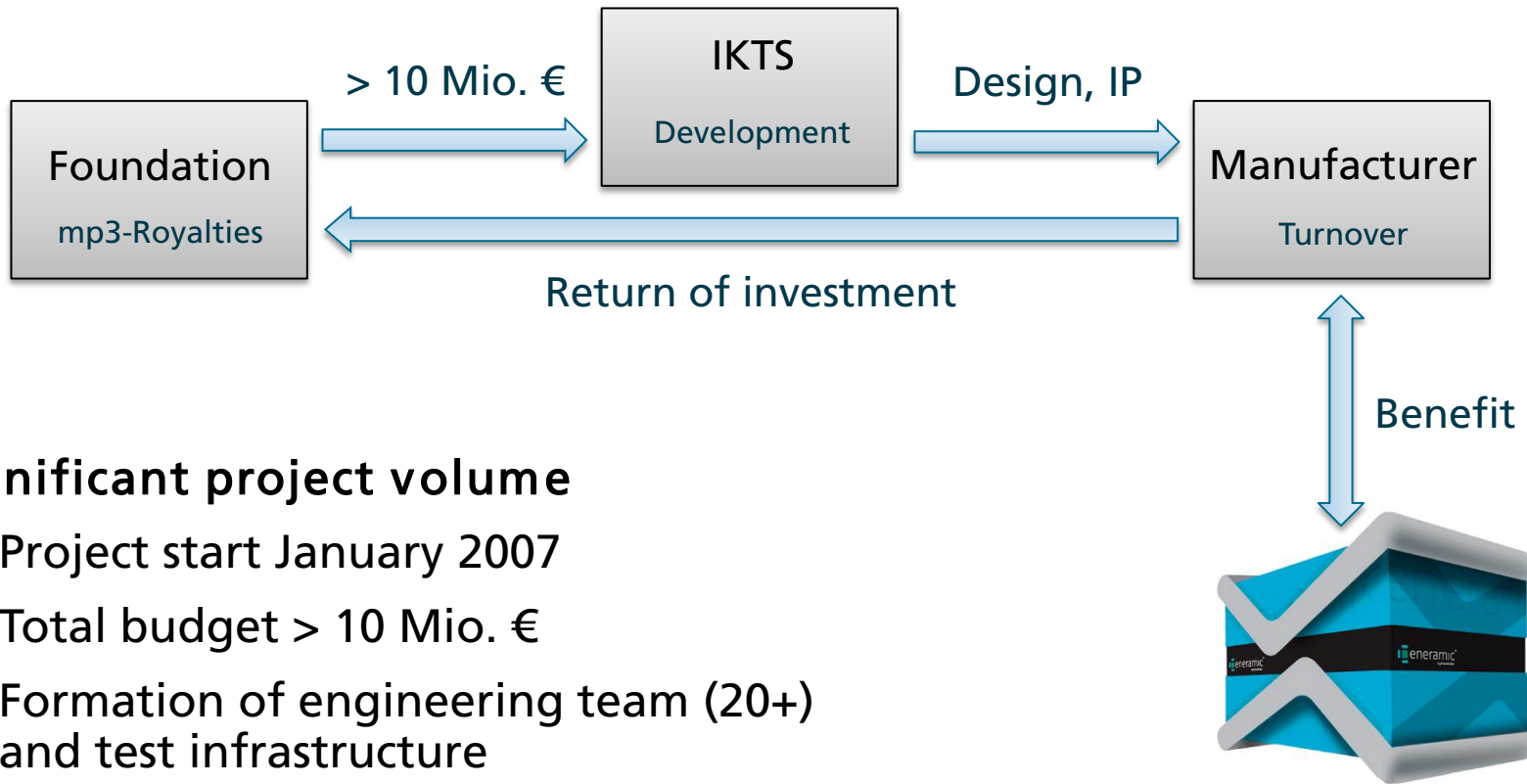

## Significant project volume

- Project start January 2007
- Total budget > 10 Mio. €
- Formation of engineering team (20+) and test infrastructure
- Scope from preliminary design to commercialization
- Development of patent clusters

# eneramic<sup>®</sup> by Fraunhofer

## Technical Status



- $\mu$ -SOFC is technically feasible
- System core in operation > 3,000 h
- Extremely compact system (< 8 kg, system core < 1.5 liter)
- Operation on commercial propane (DIN 51622), bio-ethanol and propane/butane mixtures demonstrated
- Extreme T-cycling demonstrated up to 20 K/min
- Cost-efficient production due to multilayer concept

