

EEHE International Conference, May 14th-15th, 2025, Bamberg

Measurements and Simulation-Based Characterization of eFuses

Sven Reitz, Jens Warmuth, Thomas Markwirth, Michael Reim

Fraunhofer Institute for Integrated Circuits IIS
Division Engineering of Adaptive Systems EAS



VDA

Verband der
Automobilindustrie



FAT

Forschungsvereinigung
Automobiltechnik

Outline

- Motivation
- Test Bench for Fuses and eFuses
- Modeling of eFuse
- Libraries
- Simulation Results
- Switching Heuristics
- Virtual Development and Validation
- Summary

Motivation

E/E Architectures will evolve massively over the next years

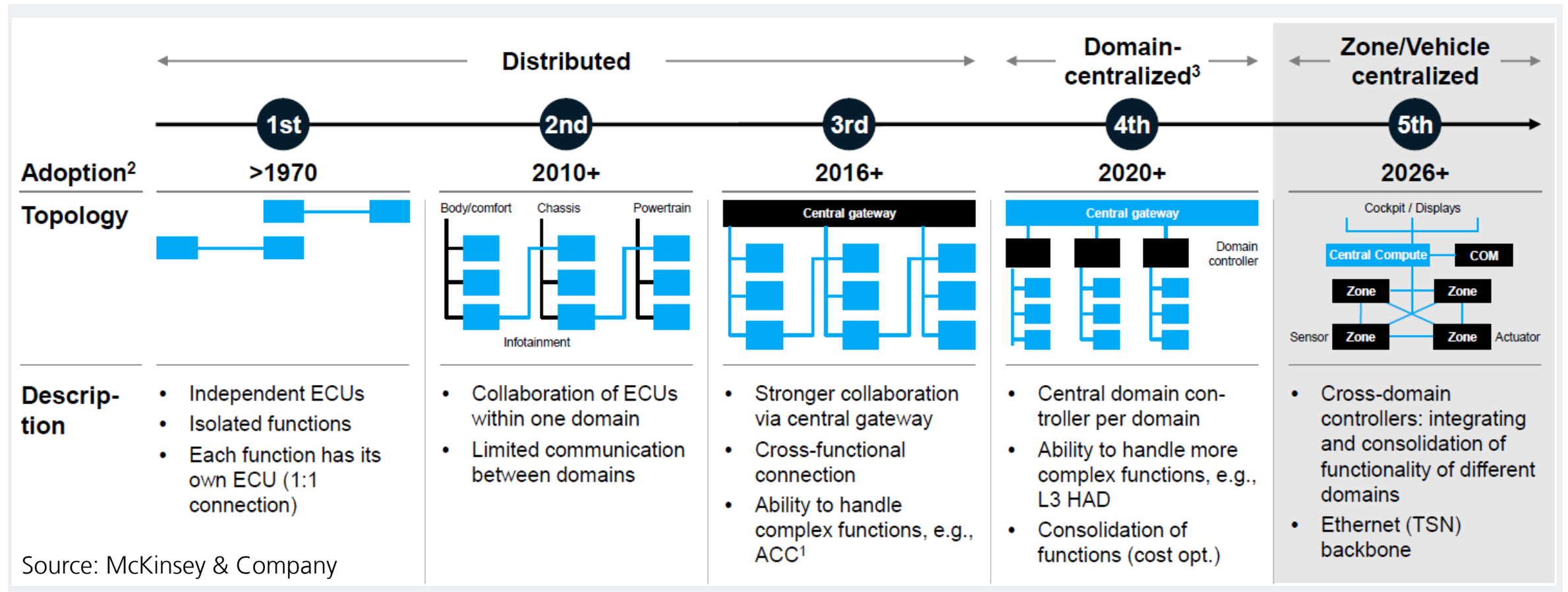

Motivation

Safety of On-Board Power Systems

Evolution of on-board power systems

- More electrification
- Increasing amount of functionality
- From support function to integral part of vehicle architecture
- Part of the overall E/E architecture including data and power network
- New architectures arising
- Contain safety relevant parts
- Are increasingly safety relevant itself
- Huge number of variants in electrical network topologies possible

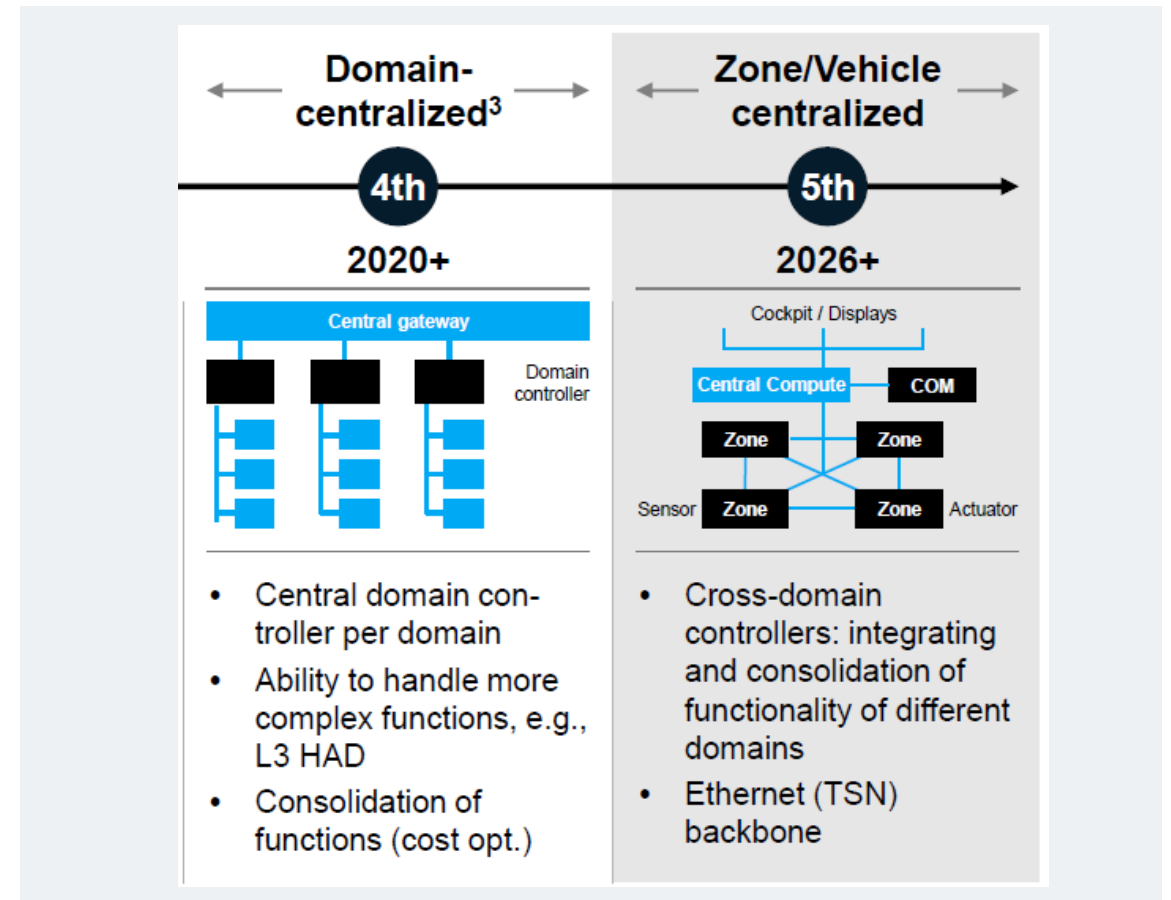

Motivation

Melting Fuses → eFuses

Advantages of eFuses

- Monitoring of voltages in addition to currents
- Centralized diagnosis and power distribution units possible
- Switching between redundant power supply paths to keep safety critical functionality available
- Switching off non safety critical loads to keep safety critical ones running
- Taking wire temperatures/heating into account (i^2t)
- Much shorter switching times compared to melting fuses
- Fine tunable trigger thresholds
- Not to be replaced in case of over current, just reenabled
- Fail safe becomes fail operational

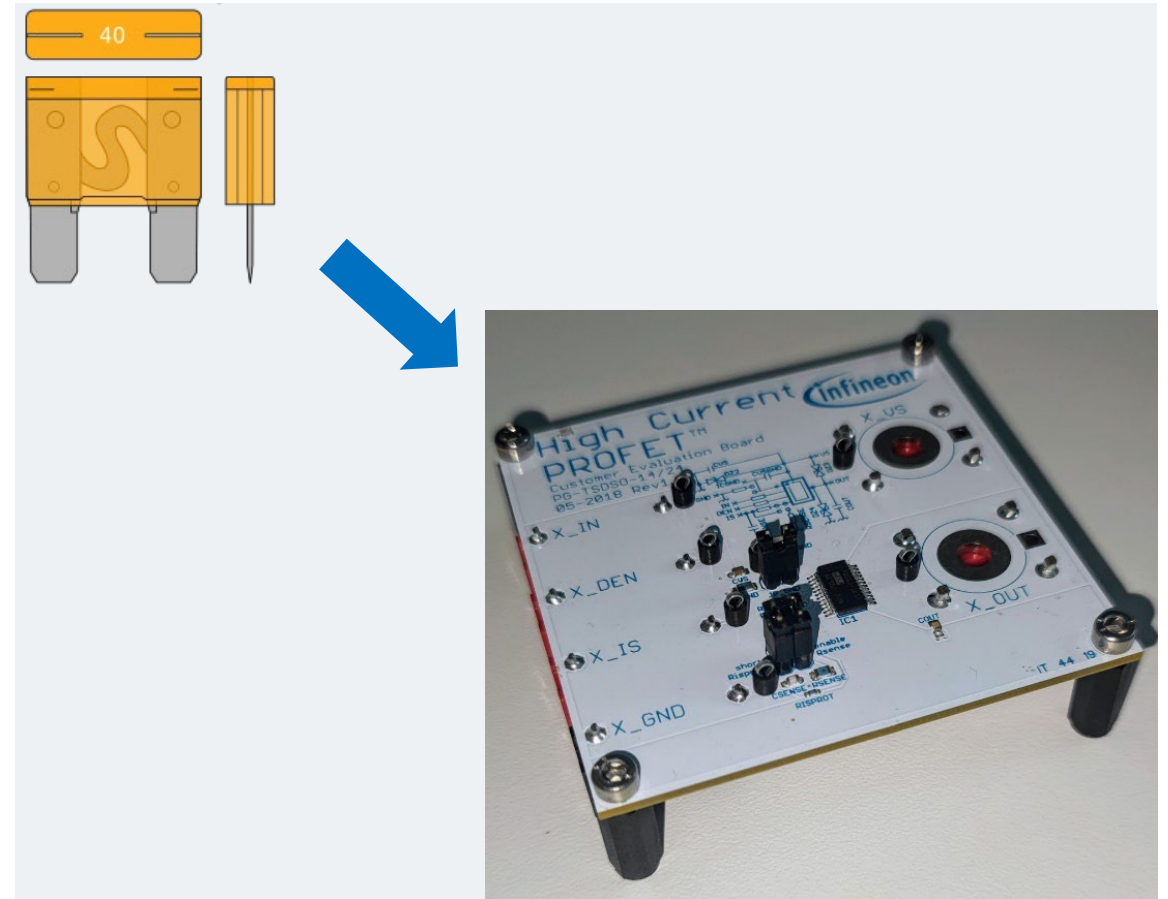

Test Bench for Fuses and eFuses

Measurements to parameterize and validate the fuse models

- Melting fuses as well as eFuses
- RC loads to emulate the input behavior of an ECU
- High-current relay initiates a short circuit fault
- Transient voltage and current pulses of the fault and the subsequent fuse switching are recorded using an oscilloscope

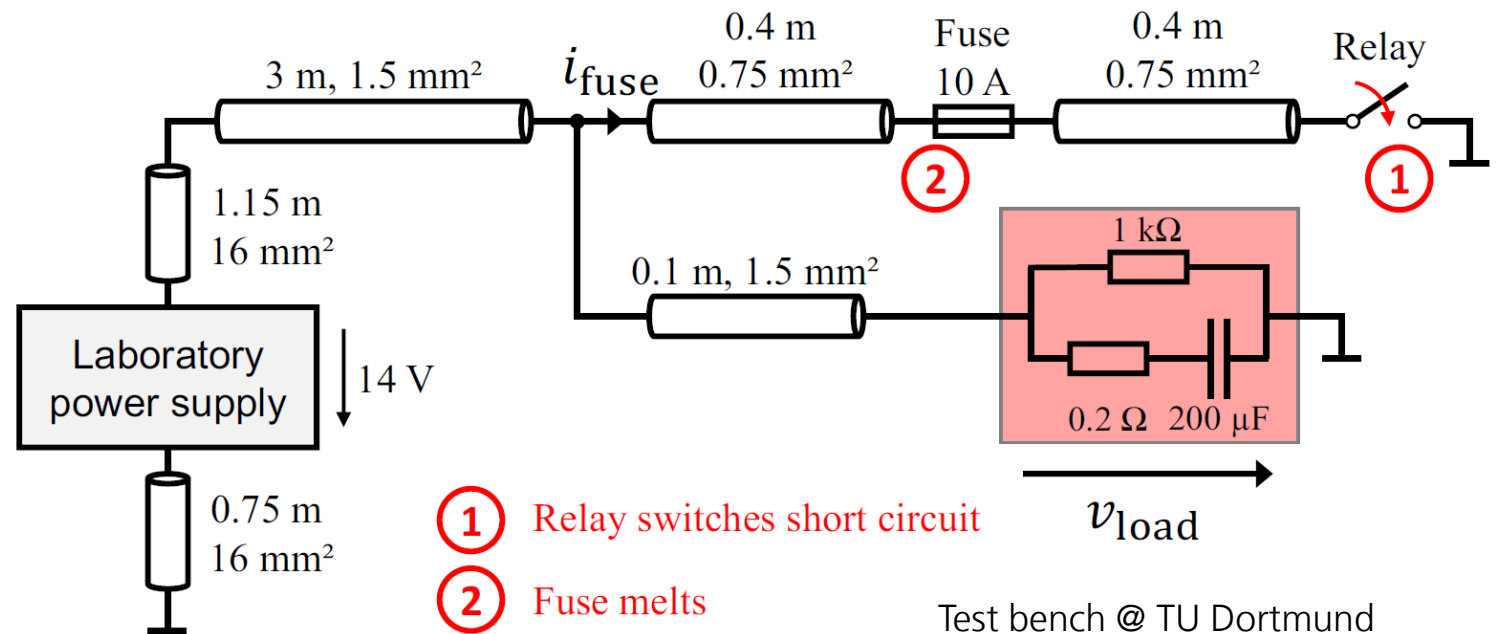

Modeling of eFuse

SimScape model by TU Dortmund

- Result of modeling, measurements, and parametrization
- Simple model to start with (electrical behavior)
- Template for Modelica model

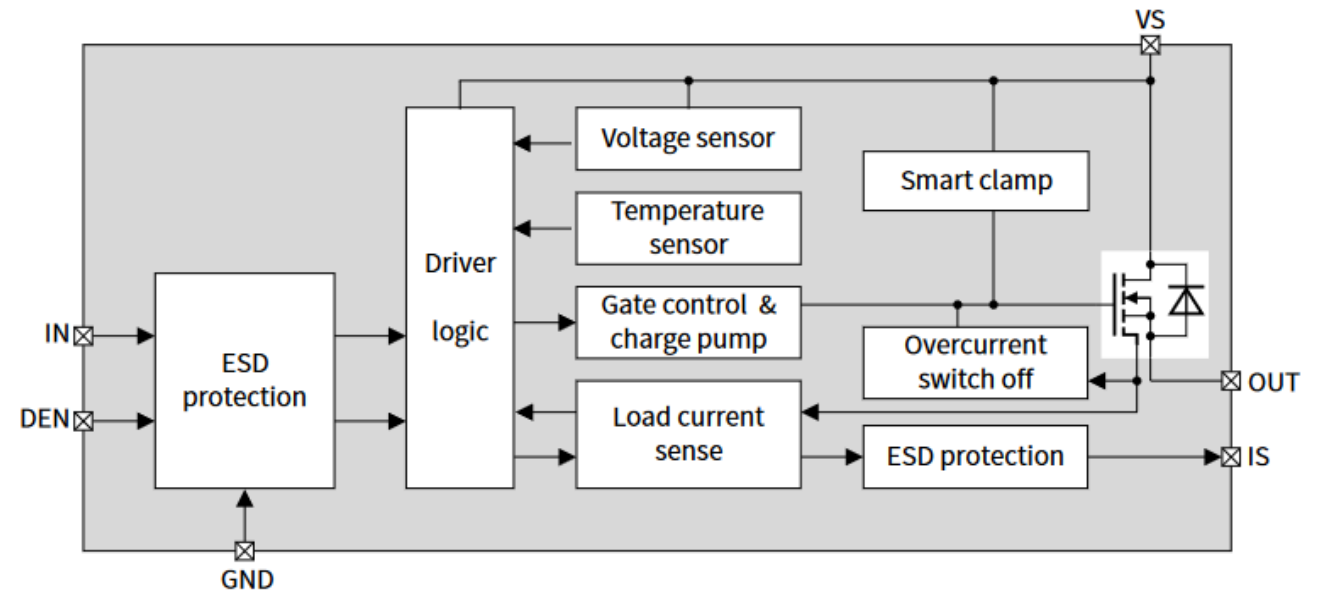
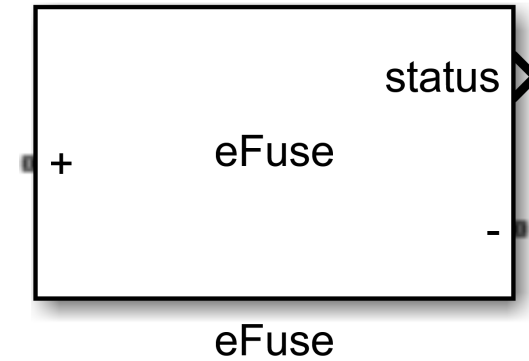

eFuse ICs Infineon BTS50005-1LUA

Modeling of eFuse

Electrical behavior

Extended Modelica model for electrical behavior

- enable – switching the eFuse on and off
 - reset – resets after triggering
 - tofire – indicates imminent triggering
 - fired – eFuse has just been triggered
-
- Parameters
 - OCP current, time, trigger current, time, time for tofire

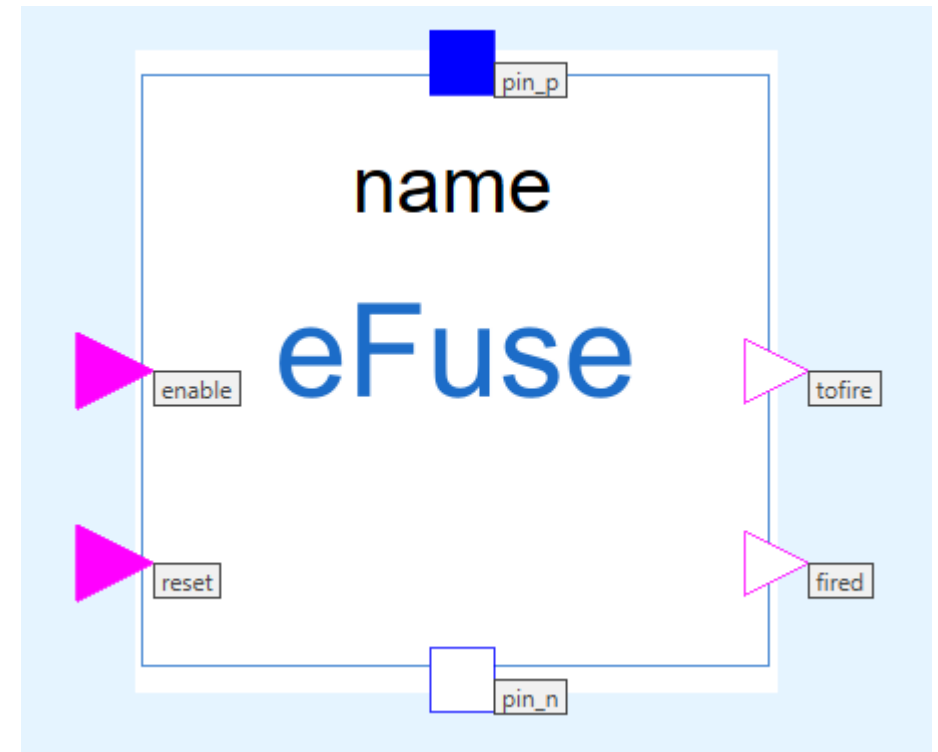

Modeling of eFuse

Thermal behavior

Modelica model for thermal behavior

- Radial model of thermal wire behavior
- Takes into account
 - thermal capacitances and resistances of wire and insulator
 - geometrical properties
 - Heat convection as well as radiation to environment
 - Ambient temperature and current flow

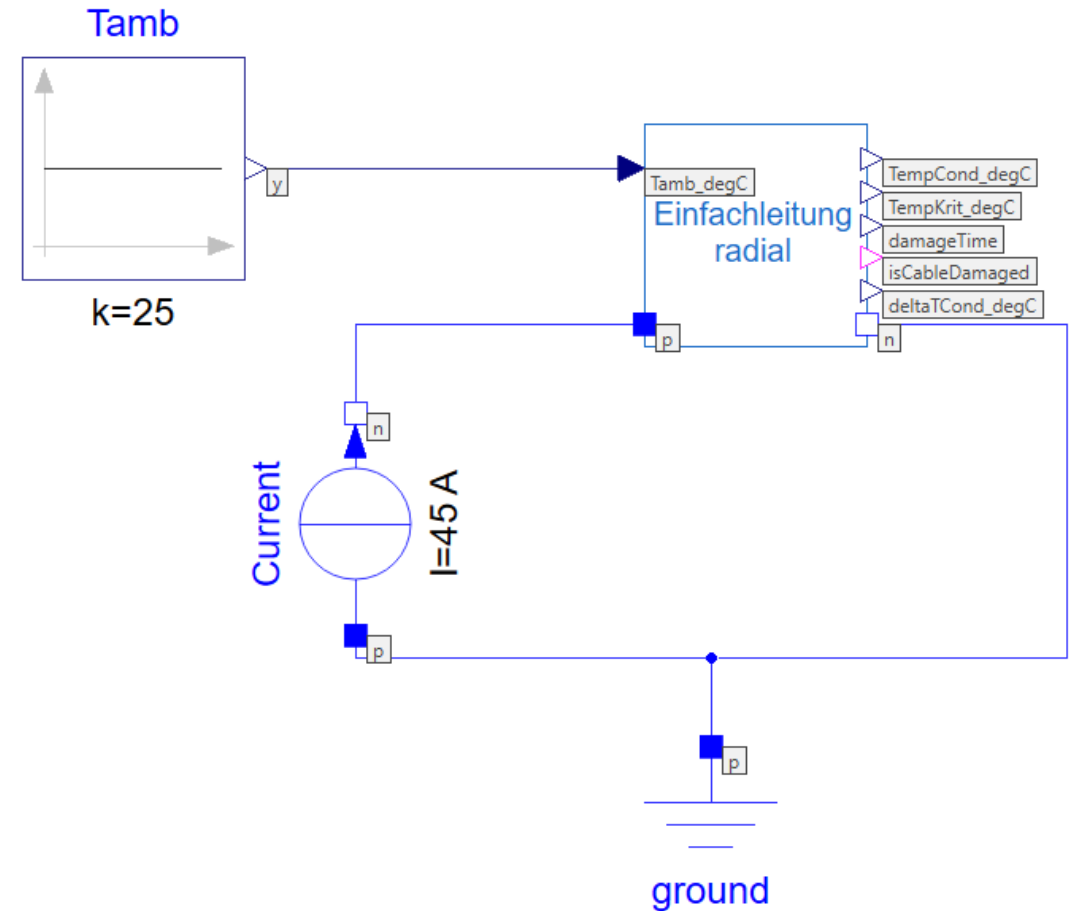

Library OnBoardSystem

PowerSupply

















- ▼ Batteries
 - Battery12VSimple
- > Internal
- ▼ Generators
 - GeneratorCF

PowerDistribution













- ▼ Fuses
 - Fuse
 - FuseGeneralSimple
 - FuseFSG
 - FuseResettable
- ▼ SmartFuses
 - SmartFuseCharacteristic
 - SmartFuseFixedType
 - SmartFuseFSG
 - SmartFuseWireModel
 - SmartFuseImaxCtrl
 - SmartFuseWireThermalCtrl
- ▼ Wires
 - Wire
 - WireGeneralSimple
 - WireGeneralExtended
 - WireModelFSG
 - WireThermal
 - > WireGeneralExtendedThermal
 - WireContactThermal
- ▼ Distributors
 - BPlus3
 - BPlus4
 - BPlus5
- ▼ Switches
 - HighSideSwitchSimple
 - HighSideSwitchSimpleThermal
- > Utilities
- ▼ Junctions
 - BPlusJunction
 - BCMJunction
 - BPosJunction
- ▼ SmartLoadController
 - SmartLoadController_Simple

Library OnBoardSystem

ECUs

- ▼  SeatECUs
 - >  Examples
 -  SCU_simple
 -  SeatECU_GolfV
 -  SeatECU_EMV
 - ▼  DoorCUs
 -  PowerWindowsCU
 - ▼  SteeringECUs
 -  EHPS
 -  KasselEBN_SteeringSequence
 - ▼  EngineECUs
 -  EngineECU_constP
 -  EngineECU_EMV
 -  EngineECU_EMV_MOSFET
 - ▼  DomainController
 - >  Examples
 -  DomainController

Loads

- ▼  ElectricalMachines
 - >  Examples
 - ▼  EngineFans
 -  EngineFan_GolfV
 - ▼  PowerWindows
 -  PowerWindow_GolfV
- ▼  Heaters
 - ▼  Windows
 - >  Examples
 -  RearWindowHeater
- ▼  Seats
 -  Examples
 -  HeaterSeat

Library OnBoardSystemFaultSimulation

ComponentFaultModels

- Connectors
 - Connector_1_pole
 - Connector_2_pole
 - Connector_3_pole
 - Connector_4_pole
 - Connector_5_pole
- Battery
- Battery_extended
- DCDC_Converter
- Generator
- Ground_stud
- Wire_fault
- PDU**

ComponentFunctionalModels

- Wire_R
- Wire_RL
- Wire_RLC
- Fuse
- eFuse**

BasicFaultModels

- Wire_break
- Arc
- Short

LoadModels

- RC_Load
- RL_Load
- Const_Power

MonitorModels

- monitorVoltage
- monitorCurrent

Simulation Results

Switch-off logic for non-safety-relevant loads

eFuse

Non-safety-critical loads

Safety relevant load
(switches from 1 to 0.5 Ω at $t=0.2$ s)

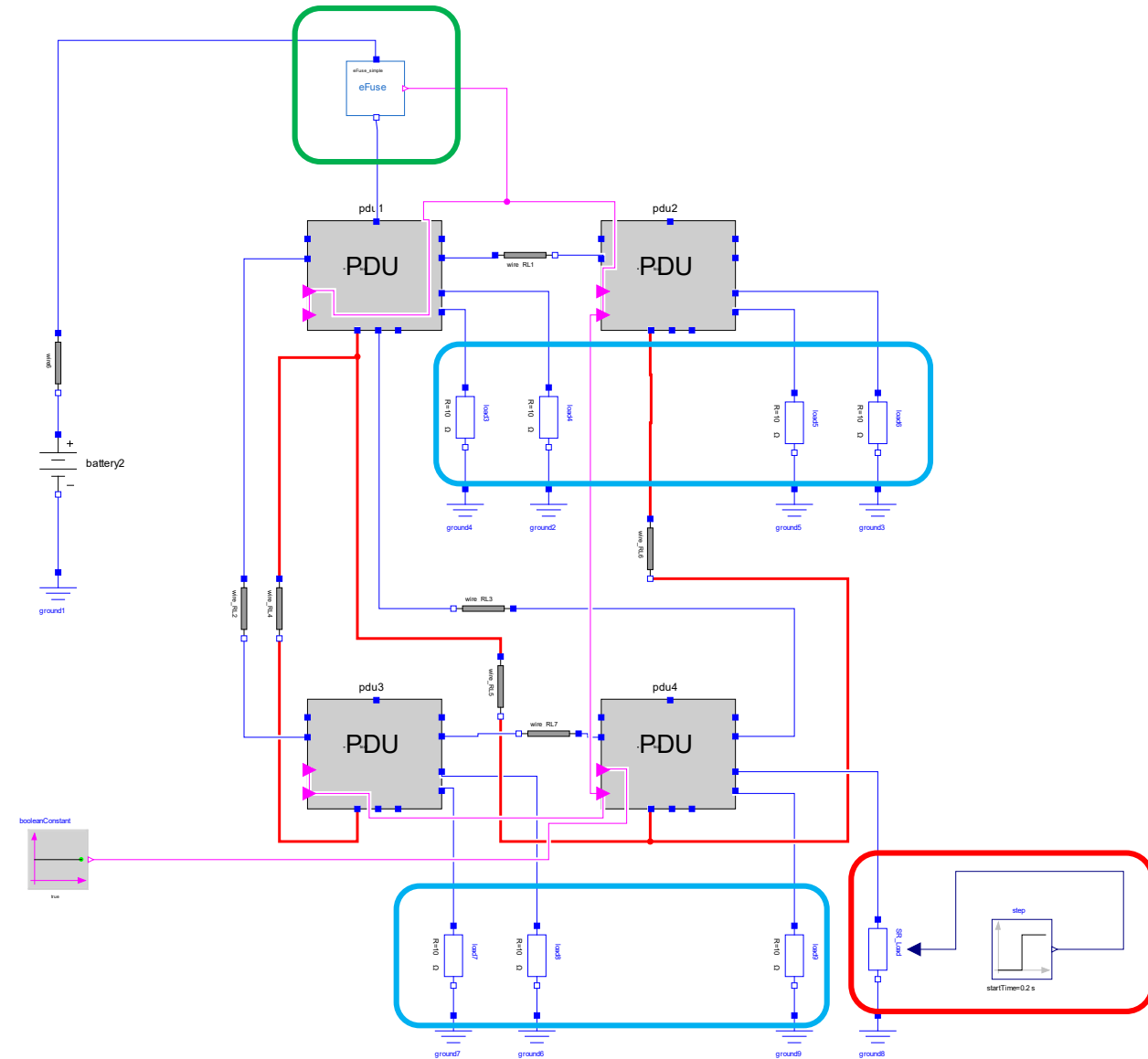

Simulation Results

Switch-off logic for non-safety-relevant loads

Voltage at safety relevant load

current through main eFuse
(25 A trigger current)

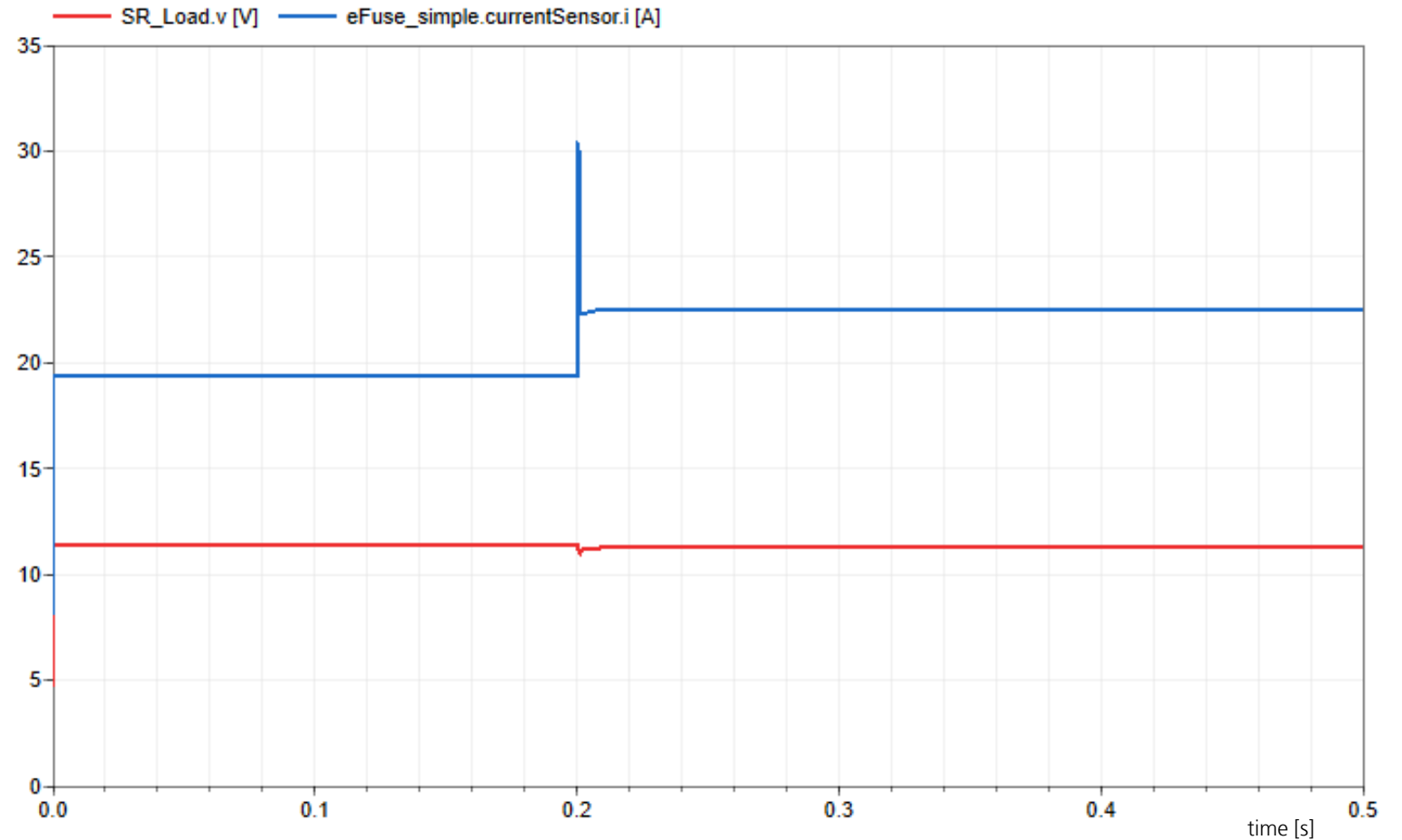

Simulation Results

Reset after firing

Multiple retries to supply critical load with power

Parameters

reenable_delay	<input type="text" value="1e-1"/>	s
maxcount	<input type="text" value="3"/>	

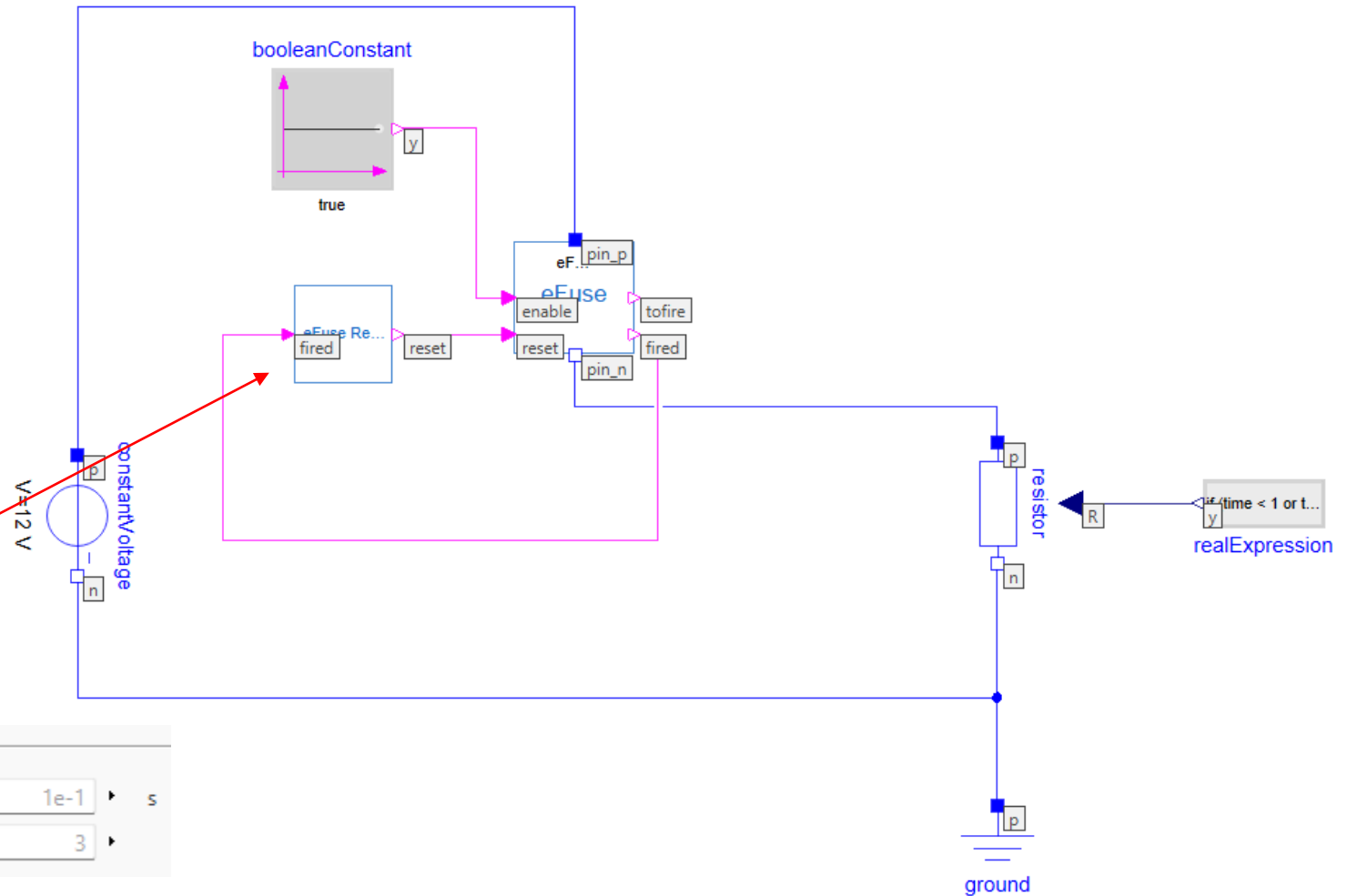

Simulation Results

Reset after firing

- Load resistance drops from 1 to 1.3 s
- eFuse fires and und will be reset three times
- **Fault-free state** of the load reached again

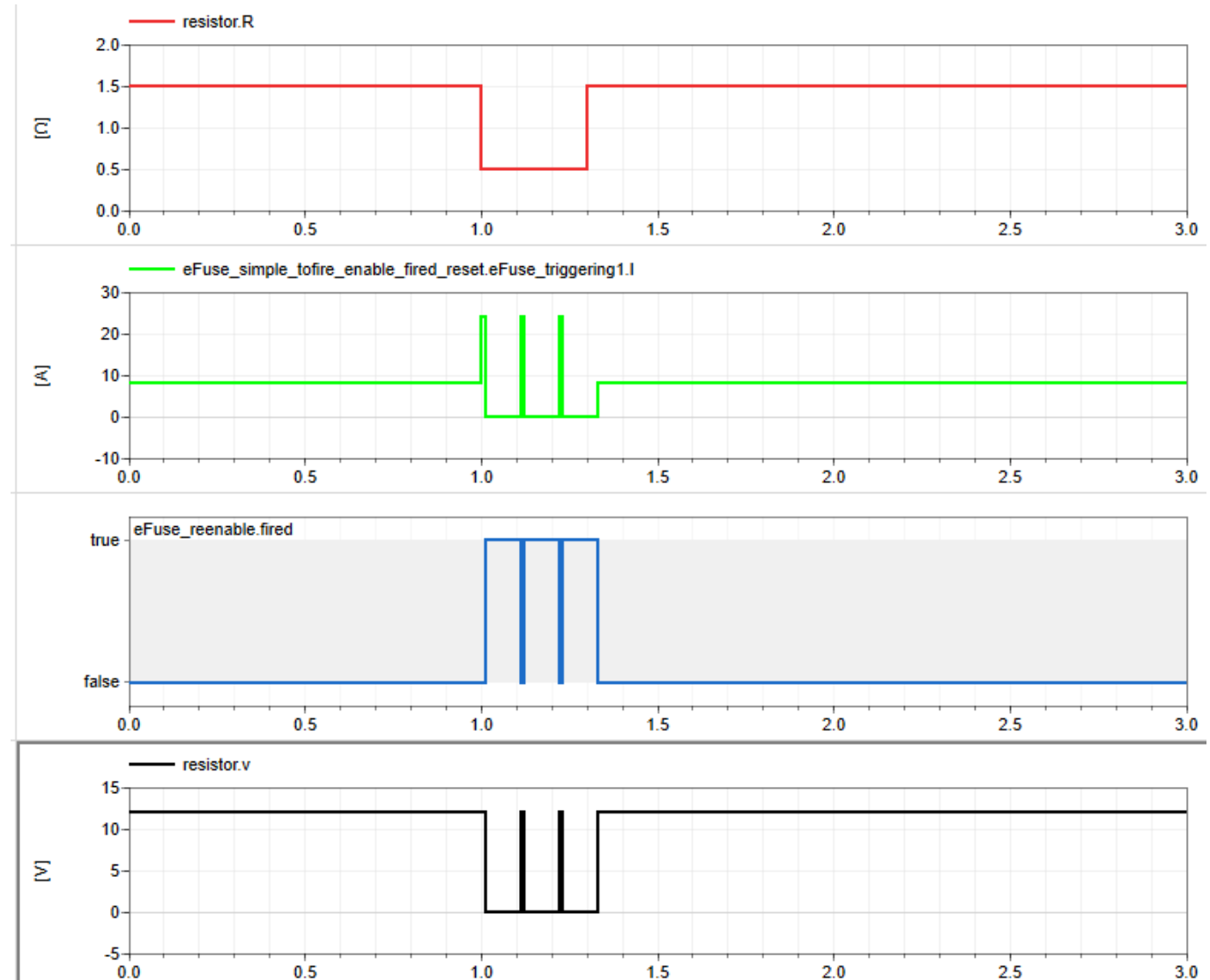

Switching Heuristics

Three levels of eFuses

- No backbone
- star-shaped backbone
- Backbone from PDU to PDU

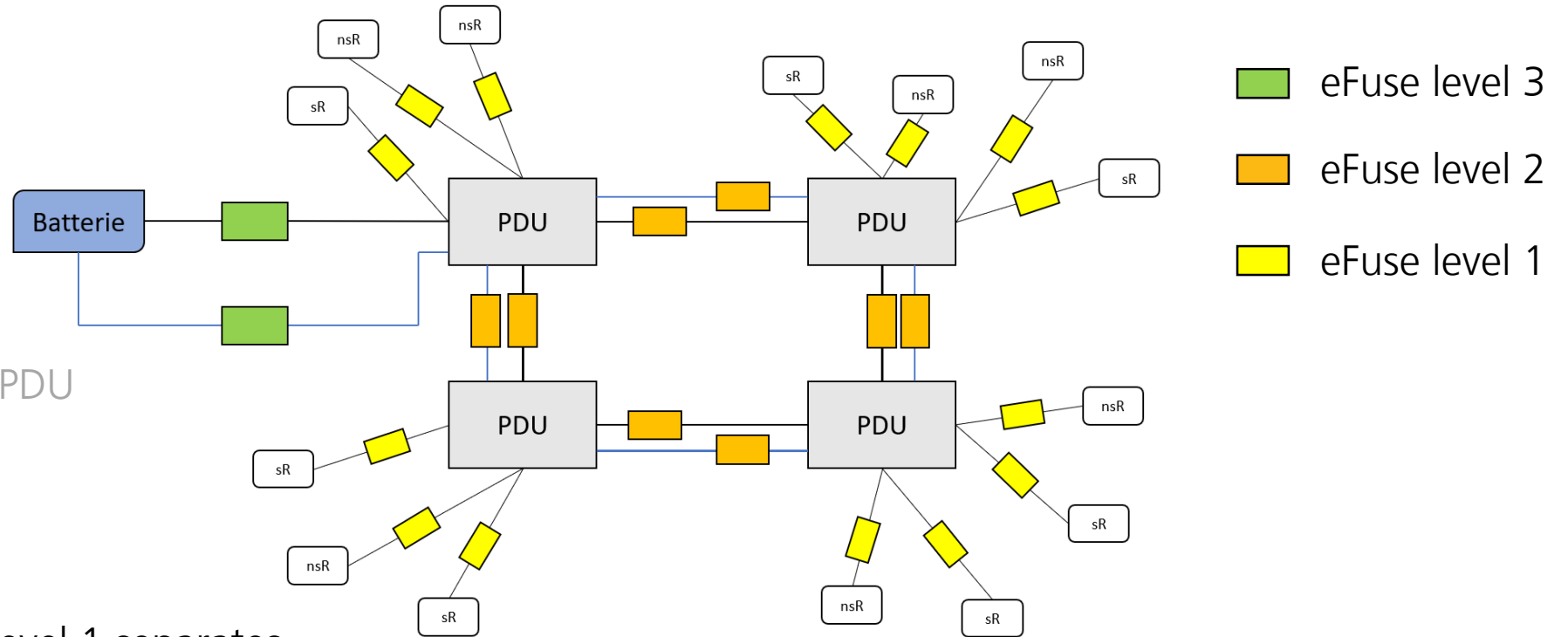

- Level 1 overcurrent → Level 1 separates
- Level 2 overcurrent & all (Level 1 no overcurrent | disabled) → Level 2 separates
- Level 3 overcurrent & all (L2 no overcurrent | disabled) & all (L1 no overcurrent | disabled) → Level 3 separates
- Switching on the backbone
- eFuses of backbone the same as eFuses of normal PDU interconnects

Switching Heuristics

Three levels of eFuses

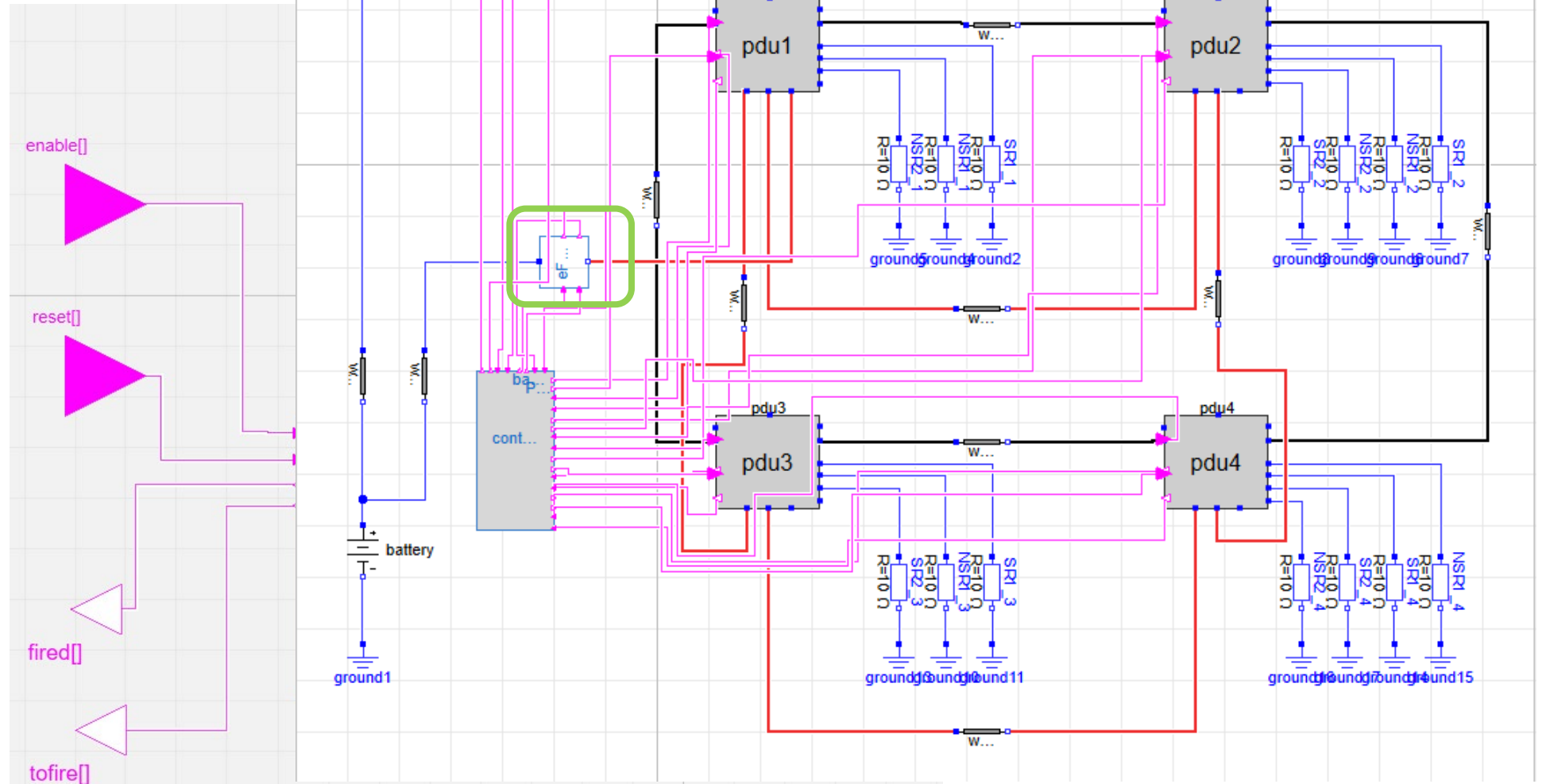

Virtual Development and Validation

Automated model generation

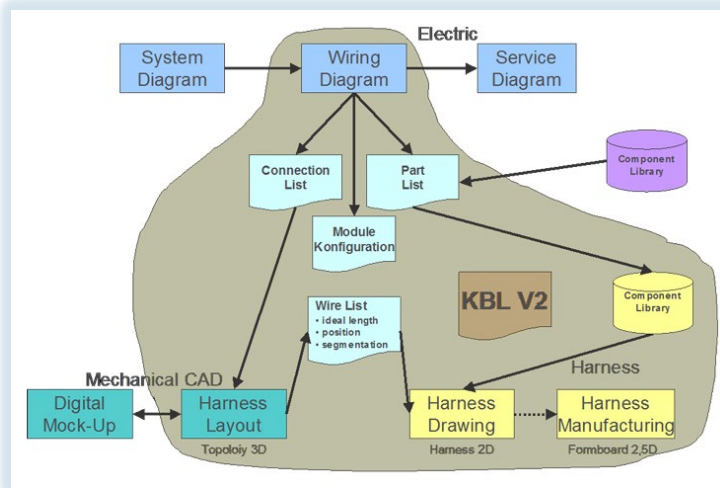

KBL/XML import



```

"topology": {
  "title": "AK30 test topology",
  "nodes": [
    { "type": "Generator", "ID": "generator1" },
    { "type": "Battery", "ID": "battery1", "parameters": { "OCV": 49.0, "number_p": 2, "number_s": 6, "comment": "Batterie18V" } },
    { "type": "Battery", "ID": "battery2", "parameters": { "OCV": 14.0, "number_p": 2, "number_s": 6, "comment": "Batterie12V" } },
    { "type": "DCDC_Converter", "ID": "DCDC_Converter1", "parameters": { "Iout_max": 200, "Vin_min": 0, "Vref": 12, "control": "pwm" } },
    { "type": "PDU", "ID": "pdu1" },
    { "type": "PDU", "ID": "pdu2" },
    { "type": "PDU", "ID": "pdu3" },
    { "type": "RC_Load", "ID": "rc_Load1", "parameters": { "resistance": 100.0, "capacitance": 1.0e-6, "comment": "SR Lenkung" } },
    { "type": "RC_Load", "ID": "rc_Load2", "parameters": { "resistance": 100.0, "capacitance": 1.0e-3, "comment": "SR ESP" } },
    { "type": "RC_Load", "ID": "rc_Load3", "parameters": { "resistance": 100.0, "capacitance": 1.0e-3, "comment": "SR Systemrechner" } },
    { "type": "RC_Load", "ID": "rc_Load4", "parameters": { "resistance": 100.0, "capacitance": 1.0e-3, "comment": "SR Systemrechner" } },
    { "type": "RC_Load", "ID": "rc_Load5", "parameters": { "resistance": 100.0, "capacitance": 1.0e-3, "comment": "SR Systemrechner" } },
    { "type": "RC_Load", "ID": "rc_Load6", "parameters": { "resistance": 100.0, "capacitance": 1.0e-3, "comment": "SR Systemrechner" } },
    { "type": "RC_Load", "ID": "rc_Load7", "parameters": { "resistance": 100.0, "capacitance": 1.0e-3, "comment": "SR Systemrechner" } },
    { "type": "RC_Load", "ID": "rc_Load8", "parameters": { "resistance": 100.0, "capacitance": 1.0e-3, "comment": "SR Systemrechner" } },
    { "type": "RC_Load", "ID": "rc_Load9", "parameters": { "resistance": 100.0, "capacitance": 1.0e-3, "comment": "SR Systemrechner" } },
    { "type": "RC_Load", "ID": "rc_Load10", "parameters": { "resistance": 100.0, "capacitance": 1.0e-3, "comment": "SR Systemrechner" } }
  ],
  "connections": [
    { "connection": {
      "type": "Wire",
      "ID": "w1",
      "startnode": "generator1.p",
      "endnode": "pdu1",
      "parameters": {
        "df_wire_cross": 2.5,
        "df_wire_length": 10.5
      }
    } },
    { "connection": {
      "type": "Wire",
      "ID": "w2",
      "startnode": "DCDC_Converter1.pin_p1",
      "endnode": "pdu5.pin_p4",
      "parameters": {
        "df_wire_cross_section": 2.5,
        "df_wire_length": 10.5
      }
    } }
  ]
}
    
```

JSON intermediate format

Modelica export

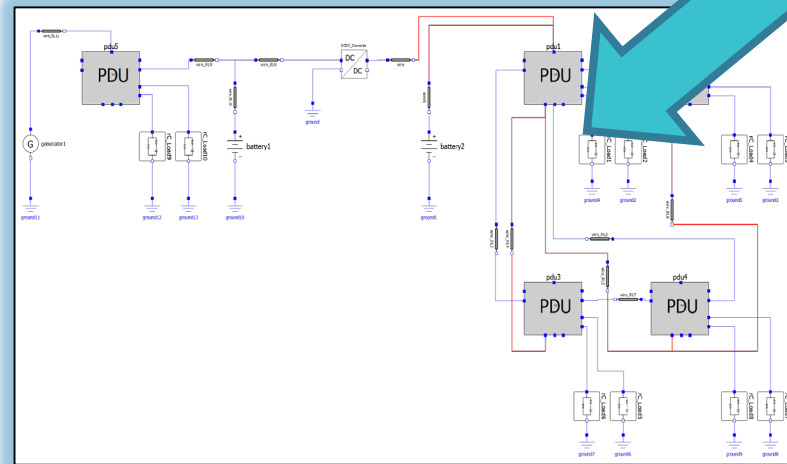

SystemC AMS export

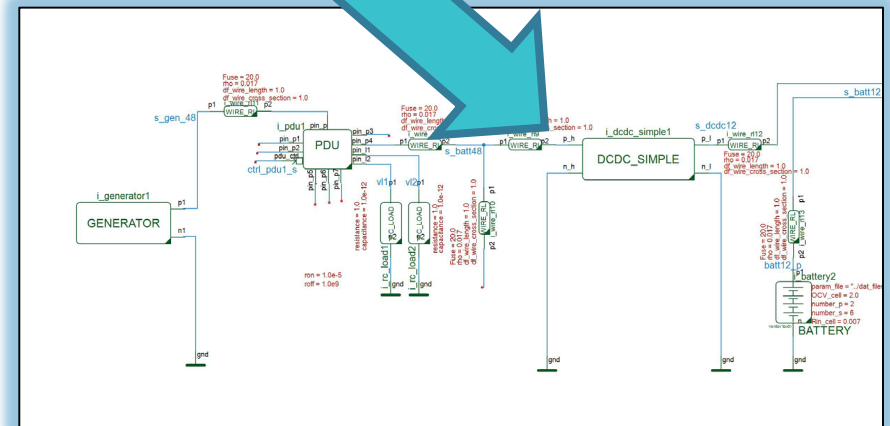

Virtual Development and Validation

Simulation using fault injection

Dynamic fault simulation

Simulation of nominal system behavior

- Simulation of relevant test cases for the design under test (DUT)
- Using typical stimuli and checks to verify fulfilment of characteristics

Clear separation between

- What to test: design under test (DUT) and
- How to test: description of stimuli and evaluation

Fault injection

- Using a fault library (open, short, overvoltage, contact resistance, ...)
- Inserting them into the DUT at possible locations

Avoiding bugs due to insertions of test artifacts

- No DUT code change required
- Faults are only inserted at runtime

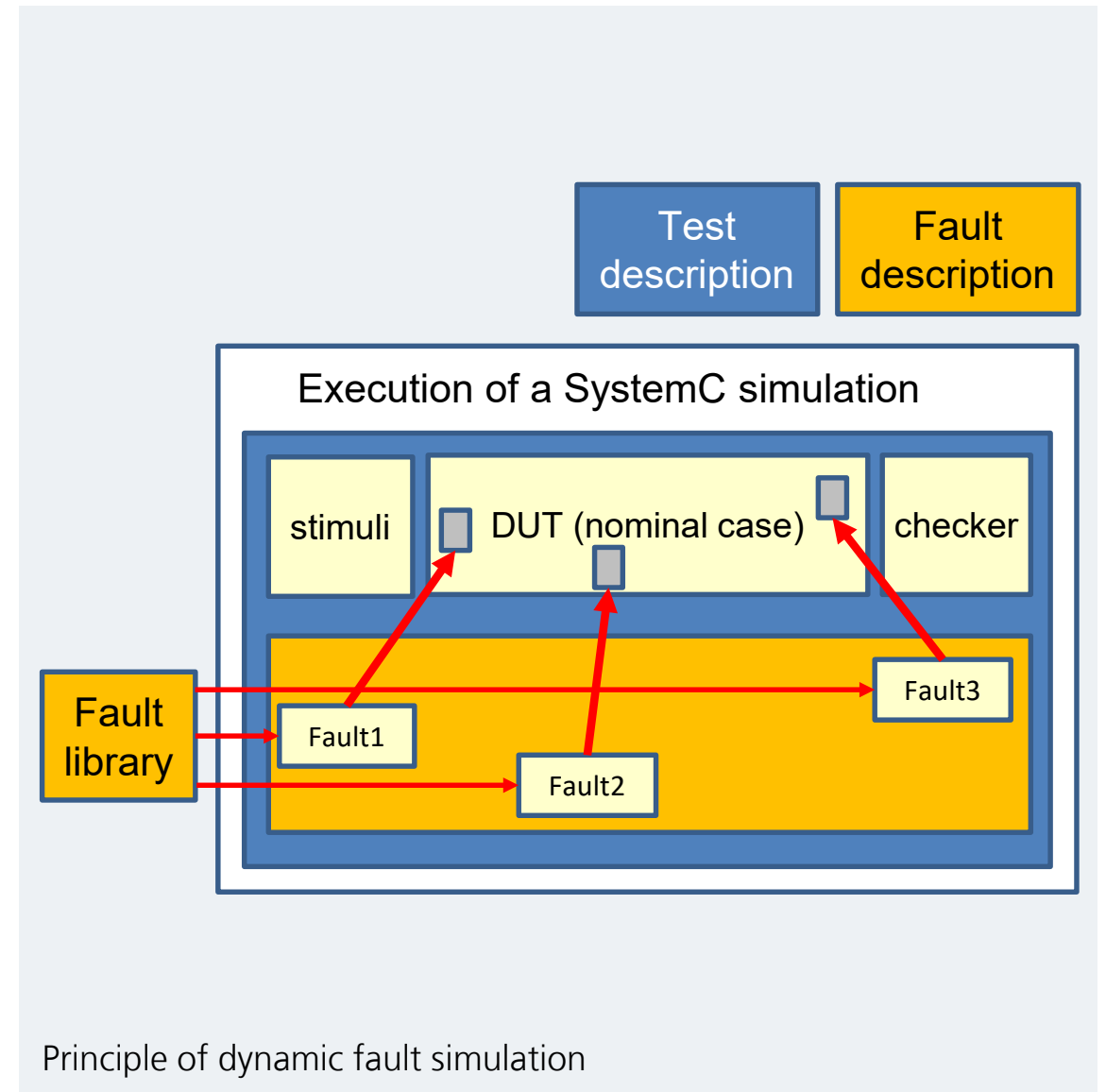

Virtual Development and Validation

Flow automation

Integrated simulation and assessment flow

Selection

- Topology variants
- Operation scenarios
- Faults (type, parameters, location, ...)

Instantiation

- Required component models
- Fault models from libraries

Automated execution

- Simulation runs in batch mode
- Collection of simulation results
- Evaluation of safety metrics

Depiction of results

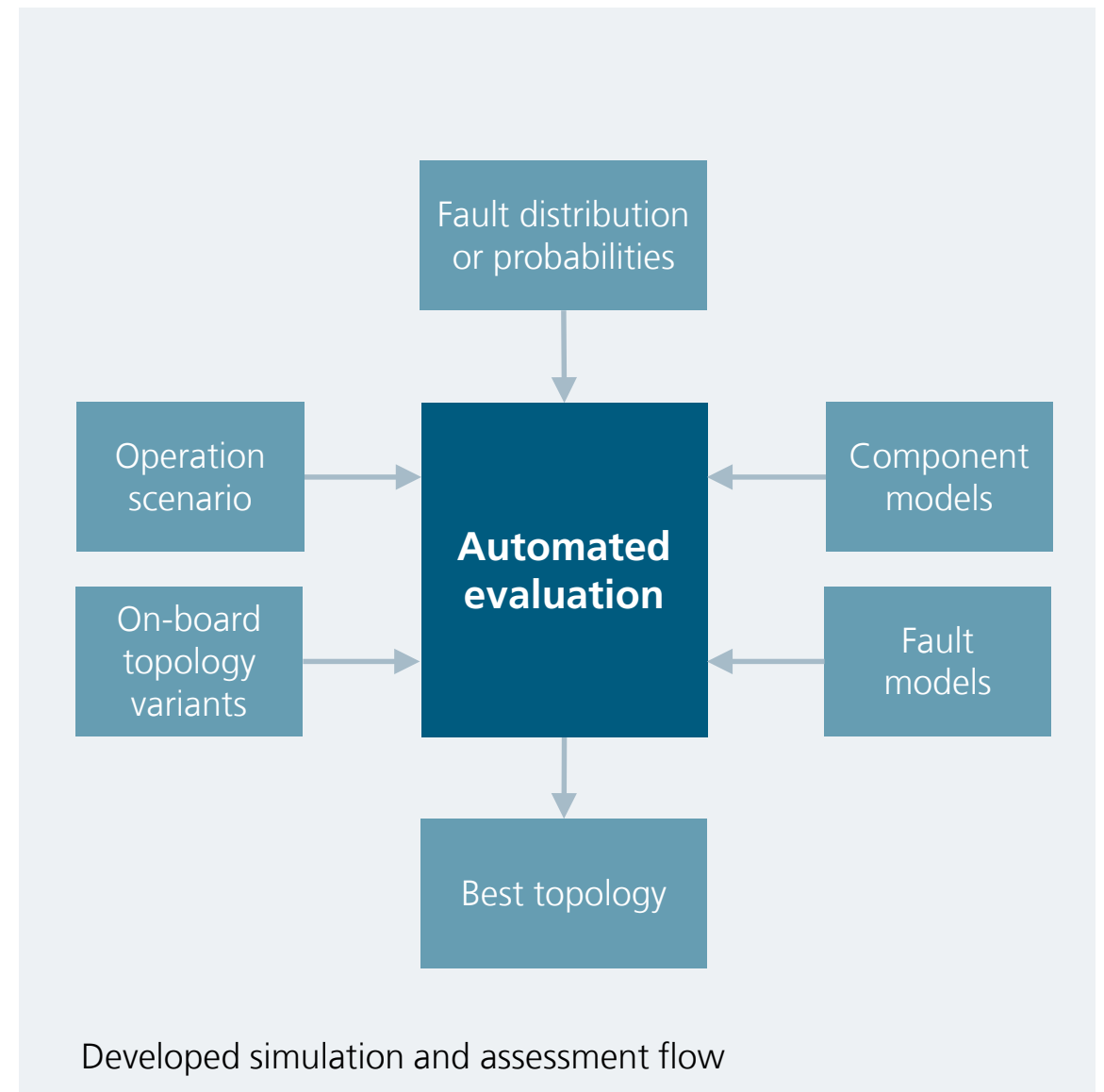

Virtual Development and Validation

Dashboard

Dashboard - Bordnetz



Basis - Topologie (.KBL Datei)

Topologie - Varianten (.MAT Datei)

Selektierte Topologievariante(n)

Generiere Modelle

Brute Force (Phase 1)

Monte Carlo (Phase 2)

Monte Carlo (Phase 3)

Übersetze Modelle

Modelle ausführen

Auswertung neu

Filter Auswahl

Boardnetz - Auswertung

ASIL A Auswahl anzeigen

Topologie	Kosten	SPFM	DC SR	SR Fehler n. beh.	SR Fehler DC gesamt	NSR Fehlern. beh.	NSR Fe
1993	2370	66 %	52 %	43	21	28 %	49
2015	2370	66 %	52 %	43	21	28 %	49
4703	2370	60 %	42 %	43	25	28 %	49
6089	2370	60 %	42 %	43	25	28 %	49
457	2350	64 %	50 %	44	22	28 %	50
95	2400	66 %	52 %	43	21	28 %	49
1985	2400	66 %	52 %	43	21	28 %	49
4169	2400	60 %	42 %	43	25	28 %	49
4191	2400	60 %	42 %	43	25	28 %	49
4673	2400	60 %	42 %	43	25	28 %	49
6081	2400	60 %	42 %	43	25	28 %	49
985	2370	60 %	40 %	44	26	28 %	50
2009	2420	68 %	52 %	43	21	28 %	49
4697	2420	62 %	42 %	43	25	28 %	49
5705	2420	60 %	42 %	43	25	28 %	49
5727	2420	60 %	42 %	43	25	28 %	49
6105	2420	62 %	42 %	43	25	28 %	49
4161	2430	72 %	60 %	43	17	28 %	49
1998	2440	60 %	42 %	43	25	28 %	49
2012	2440	66 %	52 %	43	21	28 %	49
4700	2440	66 %	52 %	43	21	28 %	49
6094	2440	66 %	52 %	43	21	28 %	49



Anzahl Topologien in Filter: 1008
 Topologien: 145-146, 151-152, 161-179-280, 289-290, 295-298, 303-306, 679-682, 687-690, 695-696, 721-722, 823-824, 849-850, 855-856, 865-866, 1233-1234, 1239, 1249-1250, 1255, 1335-1336, 1361-1362, 1367-1368, 1711-1714, 1719-1720, 1745-1746, 1831-1834, 1839-1842, 1847-1848, 2209-2210, 2215-2218, 2223-2226, 2327-2328, 2337-2338, 2343-2346, 2705-2706, 2711-2712, 2721-2722, 2

Summary

Simulation based safety assessment

Modern E/E architectures

- On-board power systems are rapidly evolving
- Electrical system becomes part of safety relevant infrastructure
- Advantages of eFuses compared to well known melting fuses

Model-based systems engineering

- Develop and test eFuse switching heuristics
- Validate fulfilment of safety goals for all investigated variants

Tool prototype

- Automated nominal and fault injection simulation
- Assessment of safety metrics and ranking of results

Future developments

Including more load components and eFuse variants in the libraries

Acknowledgements

Thanks to the Research Association of Automotive Technology (FAT) for funding the project

Thanks to the research partners in the project

Thanks to the members of the AK30 working group

Thank you for your attention!

Contact

Sven Reitz
Functional Safety and Reliability
Phone +49 351 45691-214
Fax +49 351 45691-111
sven.reitz@iis.fraunhofer.de

Fraunhofer Institute for Integrated Circuits IIS
Division Engineering of Adaptive Systems EAS
Muenchner Strasse 16
01187 Dresden, Germany
www.eas.iis.fraunhofer.de/en